

FOR INFORMATION

STEERING TRANSFER BOX

OIL LEVEL

(SILVER CLOUD II AND BENTLEY S2)

Replenishment of the steering transfer box should be carried out at intervals of 20,000 miles, when the following procedure should be adopted:-

Remove the filler plug and joint washer from the top, also the level plug and joint washer from the side of the steering transfer box having first ensured that the area around each plug is clean.

On left-hand drive cars, access to the filler and level plugs is gained by removing the panel situated under the left-hand front wheel arch.

On right-hand drive cars, access is gained to the level plug from beneath the car and to the filler plug from above.

Using a syringe, inject a quantity of the correct lubricant into the casing until it begins to flow from the level plug orifice, Allow a few minutes for the oil to assume its level, then refit the level and filler plugs, using new joint washers.

It will be noted that some oil will be lost from the steering transfer box during the first few miles of driving. This is normal and should cause no alarm.

The following lubricants are approved:-

Wakefield	Castrol Hi-press SC or Castrol Hypoy.
B.P.	Energol EP SAE 90
Shell	Spirax EP 90
Mobil	Mobilube GX 90.

FOR INFORMATION

INTRODUCTION OF LIGHTER STEERING

LEFT-HAND S2 CARS

With the introduction of lighter steering on left-hand drive S2 motor cars, it has been found necessary to restrict the oil feed to each end of the steering ram. This has been effected by reducing the number of feed holes in the two banjo bolts, which connect the power assisted steering box to the ram feed hoses, from two to one. At the same time, the diameter of the remaining feed hole has been reduced from 0.250 in. to 0.0866 in.

To avoid the possibility of the restricted banjo bolts (lighter steering) and the standard banjo bolt (which is still used to retain the steering pump feed hose to the steering box) being interchanged, the restricted bolts have been made readily indentifiable. The restricted bolts have a 0.500 in diameter turret on the bolt head in place of the Unified Thread identification of the standard banjo bolt.

Part Numbers are as follows:-

Restricted banjo bolt - connecting - steering box to ram feed hoses - UR.5972 - 2 off

Standard banjo bolt - connecting - steering box to pump feed hose - UE.2354 - 1 off

Note: On right-hand cars and left-hand drive cars, which are not fitted with the lighter steering, three standard banjo bolts (UE.2354) are required.

Applicable to the Following Chassis Numbers (Left-hand drive only).

Rolls-Royce Silver Cloud II	LSAE.41 and onwards except LSAE.443.
Bentley S2	B.192 LDW and onwards.
Phantom V	5.LCG.77. and onwards.
Bentley Continental S2	BC.135.LCZ. and onwards.
Rolls-Royce L.W.B.	LLCD.11 and onwards.
Bentley S2 L.W.B.	LLBB.30 and onwards.

FOR INFORMATION

RENEWAL OF THE OIL SEALS IN THE ROCKING SHAFT

LOWER BEARING HOUSING

When renewing either of the two oil seals in the rocking shaft lower bearing housing, it is most important to ensure that the rocking shaft itself is firmly supported against the upper bearing, during the period that the housing is removed. Failure to do this can possibly result in the upper roller bearing being dislodged and upon re-assembly the rocking shaft can trap the bearing against it's housing causing considerable damage.

Ensure, upon re-assembling the housing to the steering box, that the pointer on the lower bearing housing is correctly aligned with the markings on the mounting tube bracket. The pointer must be set in exactly the same position as the pointer on the upper bearing housing in order to give the correct pre-loading on the rocking shaft.

If it is suspected that the top roller bearing has been dislodged, and it is therefore necessary to remove the upper bearing housing in addition to the lower housing, the bearing pre-load should be re-set according to the instructions contained in the S2 Workshop Manual, (see Chapter N, Section N7).

CATEGORY C

ALTERNATIVE STEERING PUMPS

APPLICABLE TO:

All Rolls-Royce Silver Cloud II and III cars, and all Bentley S Series II and III cars fitted with power assisted steering.

DESCRIPTION:

The steering pumps used on the above cars are being discontinued. Kits, as described in Spares Information Sheet N2 are to be used for replacement purposes.

Two kits are available and are as follows:

1. RH 2657 - used in place of pump UE 9486 - late S III cars
2. RH 2658 - used in place of pump UE 9916 - S II and early S III cars.

This Service Bulletin details the fitting procedures for each kit.

PROCEDURE:

KIT NO RH 2657

Pump - to fit

1. Disconnect the battery.
2. Unscrew the steering pump pulley retaining setscrew.
3. Remove the drive belts.
4. With a syringe, remove the fluid from the reservoir.

5. Disconnect the pump to steering box pressure pipe. Secure previously removed pipe vertically to prevent fluid loss; retain the banjo and sealing rings.
 6. Remove the nuts and washers securing the pump swivel bracket to the 'B' bank cylinder head, detach the bracket and pump.
 7. Remove the pump from the bracket and remove the pulley.
 8. Mount the new pump (RH 8919) to the pump swivel bracket with four setscrews (UA 107/Z) and flat washers (UA 1251/Z).
 9. Mount the pump swivel bracket to 'B' bank cylinder head.
 10. Using Figure 1 for reference, fit the adapter (RH 8914), banjo (UE 30019), banjo bolt (UE 30020) and new sealing washers (UE 2514).
- NOTE: On left hand drive cars use banjo (UR 2507) and adapter (UR 3186).
11. Connect the hose from the steering box to the adapter and banjo previously fitted.
 12. Fit the pulley and drive belts.

Reservoir - to fit

1. Using Figure 3 as a guide drill four holes into the bulk-head, insert an anchor nut (SPC 1697) into each hole, fit the reservoir bracket (RH 8920) and secure with the four setscrews (UA 103/Z) and washers (UA 1251/Z).
- NOTE: The anchor nuts rivet themselves to the bulkhead as the setscrews are tightened.
2. Mount the reservoir to the bracket with the three setscrews (UA 105/Z) and washers (UA 1251/Z).

3

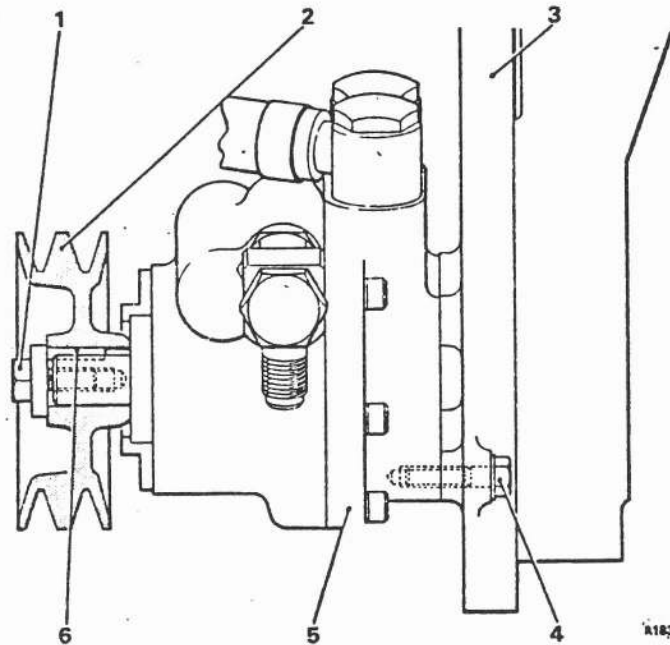

Figure 1. Fitting pump to swivel bracket

1. Pump pulley setscrew and washer.
2. Pump pulley.
3. Swivel bracket.
4. Pump to swivel bracket setscrew (UA 107/Z) and washer (UA 1251/Z).
5. Pump RH (8919).
6. Key.

Hoses - to fit

1. Using Figure 2 and Figure 3 as a guide, connect a hose, cut from RH 8912, between the pump and reservoir (pump return line).
2. Connect a hose cut from RH 8912, between steering box and reservoir (steering box return).
3. Connect a hose, cut from RH 8913, between the pump and reservoir.
4. The hoses should be clipped as shown.

System - to fill and prime (Series III cars)

1. Fill the system with approved fluid to just above the filter.
2. Start the engine and allow to idle.
3. Set the steering such that the hydraulic ram is in its most forward position. Right-hand drive - left-hand lock.
Left-hand drive - right-hand lock.
4. Remove the protective cap, fit a bleed pipe to the ram bleed nipple and insert the open end into a clear container.
5. Unscrew the bleed nipple sufficiently to allow fluid to pass into the container.

Ensure the reservoir fluid level is maintained during this process.

6. Continue bleeding until all air is expelled. Close the bleed nipple.
7. Return the steering to the straight-ahead position and re-check the fluid level of the reservoir.

NOTE: On some series III cars, a bleed nipple is also located on the rocker shaft housing of the box.

System - to fill and prime (Series II cars)

1. Fill the system with approved fluid to just above the filter.
2. Start the engine with the front wheels of the car just raised off the ground and allow to idle.
3. Turn the steering lock-to-lock until all air and noise is eliminated from the system.

5

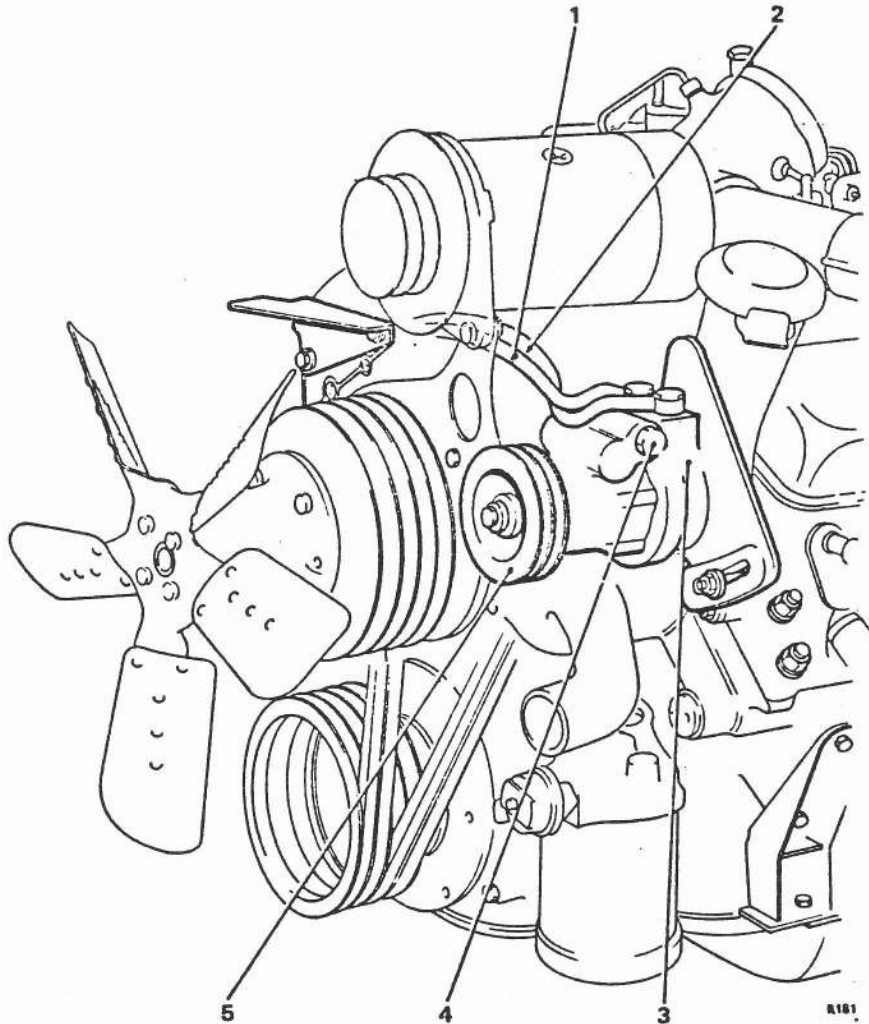

Figure 2. Pump in position

1. Hose cut from RH 8913.
2. Hose cut from RH 8912.
3. Pump and swivel bracket.
4. Pump to steering box connection.
5. Pump pulley.

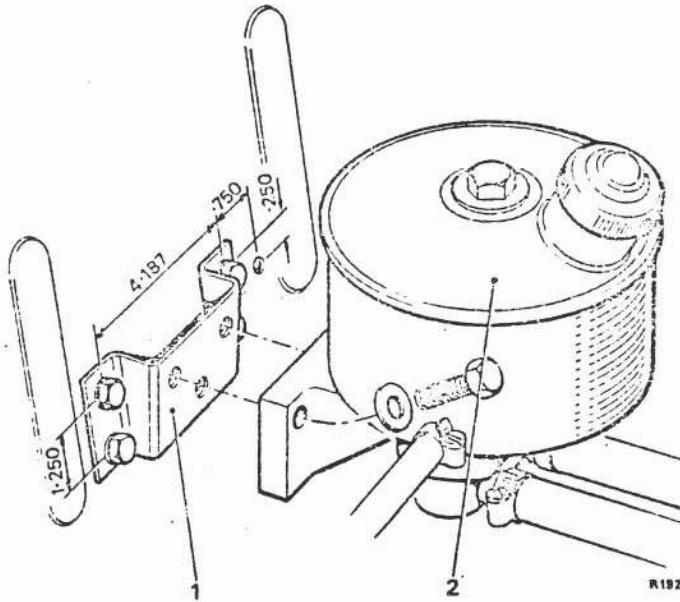

Figure 3. Fitting reservoir mounting bracket RH 8920 to bulkhead.

1. Bracket (RH 8920).
2. Reservoir.

PROCEDURE:

KIT RH 2658 - (Cars not fitted with refrigeration)

The procedures are the same as for Kit RH 2657 with the following exceptions:

1. The new pump swivel bracket (UE 9850) supplied, should be fitted in place of the existing bracket.
2. The steering box to reservoir return pipe should be disconnected, the steering box end banjo bolt retained, the hose discarded and a new hose, cut from PH 8912, fitted as Figure 2. The banjo bolt, with new seals, should be fitted with the new banjo (UE 30018) to the steering box.

NOTE: RH 8912 and RH 8913 are supplied in bulk. The lengths used in the previous procedures should be measured on the car.

TIME ALLOWED

Kit RH 2657 - 5 hours

Kit RH 2658 - 5 hours

