

**PROPELLER SHAFT  
AND UNIVERSAL  
JOINTS**

**F**

CANCELS SERVICE BULLETIN NO.  
CB-81. REF. SB/TJ.2/ET. 13.12.57.

PROPELLER SHAFT FRONT JOINT OIL SEAL UG.2995.

The propeller shaft front joint has recently been modified to improve the lubrication and reduce wear. This involves a modified propshaft and seal to permit the use of Wakefield Castrol Hi-press S/C oil as a lubricant in lieu of the grease used in the earlier design.

The components are not interchangeable except as a complete joint and front shaft assembly, and no attempt must be made to fit an oil seal to an assembly of the grease lubricated pattern. Components of the original pattern are still available for replacement purposes.

Shafts are stored with a slave face plate bolted on the joint end face. This maintains a clamping load on the end cover and Klingerite joint, thus ensuring that no loss of lubricant can occur. This should not be removed until immediately prior to fitting. When removing a shaft from the chassis for any reason, the same precaution should be observed, and a plate fitted unless the shaft is to be replaced immediately, when it may be stood upright to prevent oil leakage.

The shafts are balanced after filling with 100 c.c. of Hi-press S/C oil, and when fitting on a car it is necessary to readjust the oil seal to suit the propshaft length on the particular car. The importance of this has been stressed by failures due to incorrect installation.

On fitting the propshaft, it is essential to adjust the rear end of the boot to give an overall length of 1.450" in order to prevent folding of the seal, piercing of the rubber by retaining clips, or undue stretching. The clips must be positioned close to the seal lips. This applies particularly to the rear clip which would otherwise chafe and pierce the rubber seal.

When adjusting the boot, the rear clip should be slackened only enough to permit sliding on the shaft, or loss of oil will result.

FOR INFORMATION

PROPELLOR SHAFT FRONT UNIVERSAL COUPLING

Significant engineering refinements have been introduced from time to time on the front universal coupling with the two-fold objective of increasing its service life and improving balance retention of the propellor-shaft.

Fig. 1. shows at a glance the modifications incorporated on the front universal coupling used on 'S' Type cars in current production.

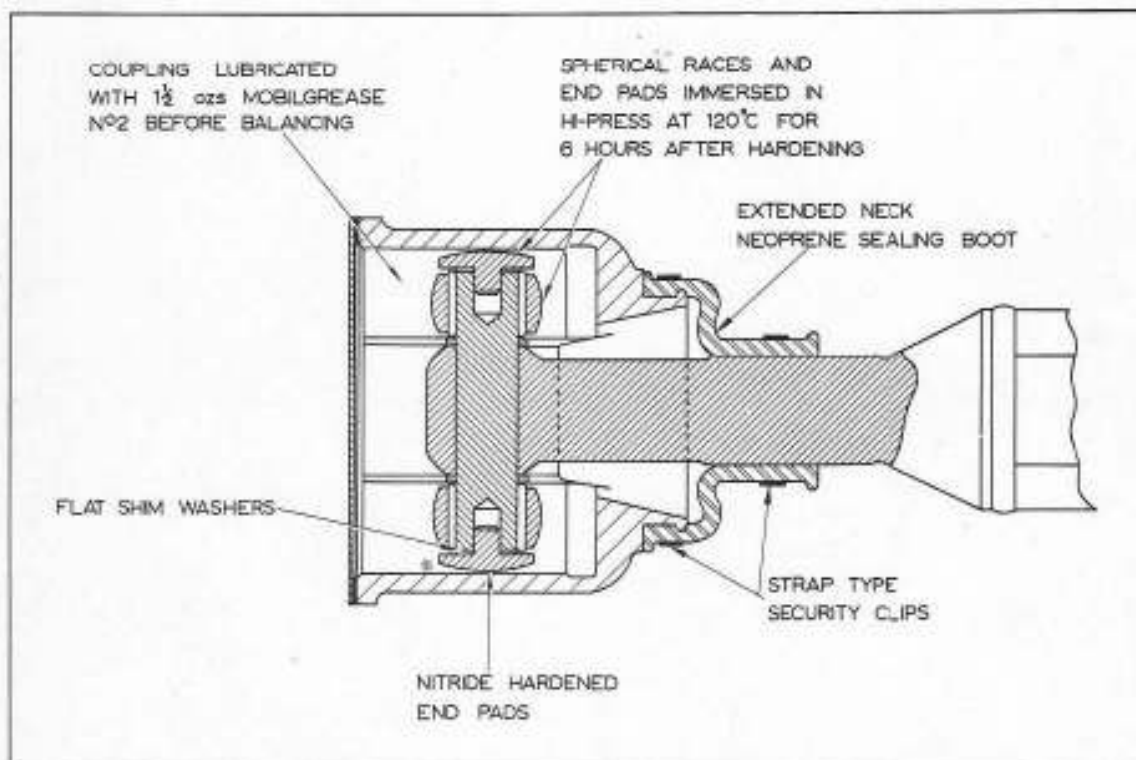

Fig. 1.

Early History

Complaints of propellor-shaft vibration investigated on early 'S' Type cars, revealed that premature wear of the mechanical elements of the coupling could often be attributed to splitting of the rubber sealing boot, with consequent loss of grease and ingress of foreign matter.

Early development work was, therefore, directed towards increasing the mechanical strength of the sealing boot. This was achieved by altering the elastomer specification from rubber to neoprene together with detail dimensional changes. The dimpled band security clips Part Nos. UG.1653/4 remain unchanged.

Satisfactory results have been obtained in service with this stronger sealing boot, Part No. UG.3162, and it is therefore supplied as a service replacement item.

#### Further Development:

For a limited period of time, Hi-Press Oil was specified as a lubricant for the coupling in order to gain service experience and assess the potential advantages of using an extreme pressure lubricant in this type of application.

A redesigned sealing boot of non-Convolute form was produced to accommodate the change of lubricant and to ensure that it is confined within the outer lobes of the coupling body. An early alteration in the synthetic rubber specification of the redesigned boot to neoprene was found necessary to overcome initial manufacturing difficulties. At the same time, the dimpled band clip Part No. UG.1653 originally retained for use with this boot together with the reduced diameter dimpled band clip Part No. UG.3021, were superseded by 14 S. W. G. wire type security clips Part Nos. UG.3522/3.

The Part No. of the Neoprene sealing boot is UG.3543, and this also is supplied as a service replacement item.

Since the redesigned boot seals on the stem of the knuckle end of the shaft, a machined sealing land of reduced diameter is provided. As it is not possible to fit this boot without dismantling the coupling from the shaft, the width of undercut behind the sealing land is sufficient to enable the coupling body to be pushed along far enough to allow the cross-pin and spherical races to be assembled.

Concurrent with these changes, the opportunity was taken of introducing further engineering refinements into the ball and trunnion coupling.

The possibility of variation in dynamic balance occurring due to compression of the wavy washers fitted between the end pads and the cross-pin, has been countered by deleting the wavy washers and substituting flat shim washers. These are selected to give zero clearance of the cross-pin and end pads in the coupling lobes.

As heat is necessary to obtain the full benefit of using an Extreme Pressure lubricant, the spherical races and end pads are now immersed in Hi-Press Oil at 120 °C for 6 hours after hardening. This pre-treatment is considered preferable to relying on local heat generation in service and should prevent any fretting occurring at the contact areas of the spherical races and end pads. In addition, a change in the material specification from a case hardening to a nitriding steel has been made for the end pads.

#### Recent Modifications

Following an extensive trial period during which Hi-Press Oil has been used for coupling lubrication, it has recently been decided to revert to grease lubrication on Production and in Service, but retain the beneficial Hi-Press pre-treatment for the spherical races and end-pads. Factors which have influenced this decision include reduced leak consciousness, freedom from coagulation and easier servicing of the coupling.

Consideration has also been given to the possibility that a foul can occur between the clamping screw and nut of the small diameter wire clip and the annular face of the sealing boot (UG. 3543).

As an insurance against the boot being damaged in this manner, the clip has been repositioned further away from the seal face by extending the neck of the boot 0.575 ins. together with a corresponding increase in width of the sealing land on the shaft stem. The Part No. of this long neck sealing boot is UG. 3553, and it is permissible to use this latest seal as a service replacement when overhauling shaft assemblies originally fitted with the short neck sealing boot.

Strap type security clips Part Nos. UG. 3554/5 have been adopted with this long neck seal, the shorter clip being positioned as near as possible to the rear of the neck. These clips are of a more compact design and by the nature of their constructions exert an evenly distributed radial clamping pressure.

Fig. 2. shows a comparison between the convoluted, short and long neck grease sealing boots and their associated clips. After installing a propellor-shaft fitted with either a short or long neck sealing boot, it is essential that the annular face of the seal is not restrained from assuming its free state.

4

The rear clip should therefore be slackened sufficiently to allow the neck to slide and relieve any strain from the seal, and finally re-tightened.

Service Bulletin CB-81, Section F specified that the fitted overall length of the short neck boot should be 1.450"; this dimension should be increased to 1.950-2.000" in the case of the long neck sealing boot.



Fig.2

FOR INFORMATION

PROPELLER SHAFT UNIVERSAL JOINT -  
FRONT COUPLING.

The bolts securing the front coupling of the propeller shaft to the gearbox flange should be checked for tightness at the 5,000 miles Scheduled Maintenance Service.

If, for any reason, this joint has to be disturbed, the securing bolts must be re-tightened after a run of approximately 10 miles. This is due to the fact that a slackening of these bolts can occur due to settling of the gasket between the joint faces.

The correct torque value is 42 - 45 lb. ft.

It has now been established that if this joint appears externally dry, grease replenishment at the 20,000 miles service IS NOW NO LONGER NECESSARY. No further maintenance is required, apart from the torque tightness check as already described.