

ROLLS-ROYCE AUTOMATIC GEARBOX

SECTION 7—REAR PUMP AND GOVERNOR

To remove the rear pump and governor, it is unnecessary to remove the gearbox from the car. Drain the oil as described in Chapter 2, then remove the following units

- Sump and side cover (see Section 3).
- Control valve unit (see Section 4).
- Parking brake bracket (see Section 5).
- Front and rear servo units (see Section 6).

If the governor only is to be removed, it is not

necessary to remove the two servo units.

Governor — To remove

Scrub correlation marks on the edge of the governor drive flange and the governor body to ensure correct assembly, then unscrew the two retaining setscrews and separate the governor assembly from its driving flange.

If the gearbox is removed from the car, hold the output shaft to prevent the governor from turning whilst the two setscrews are removed.

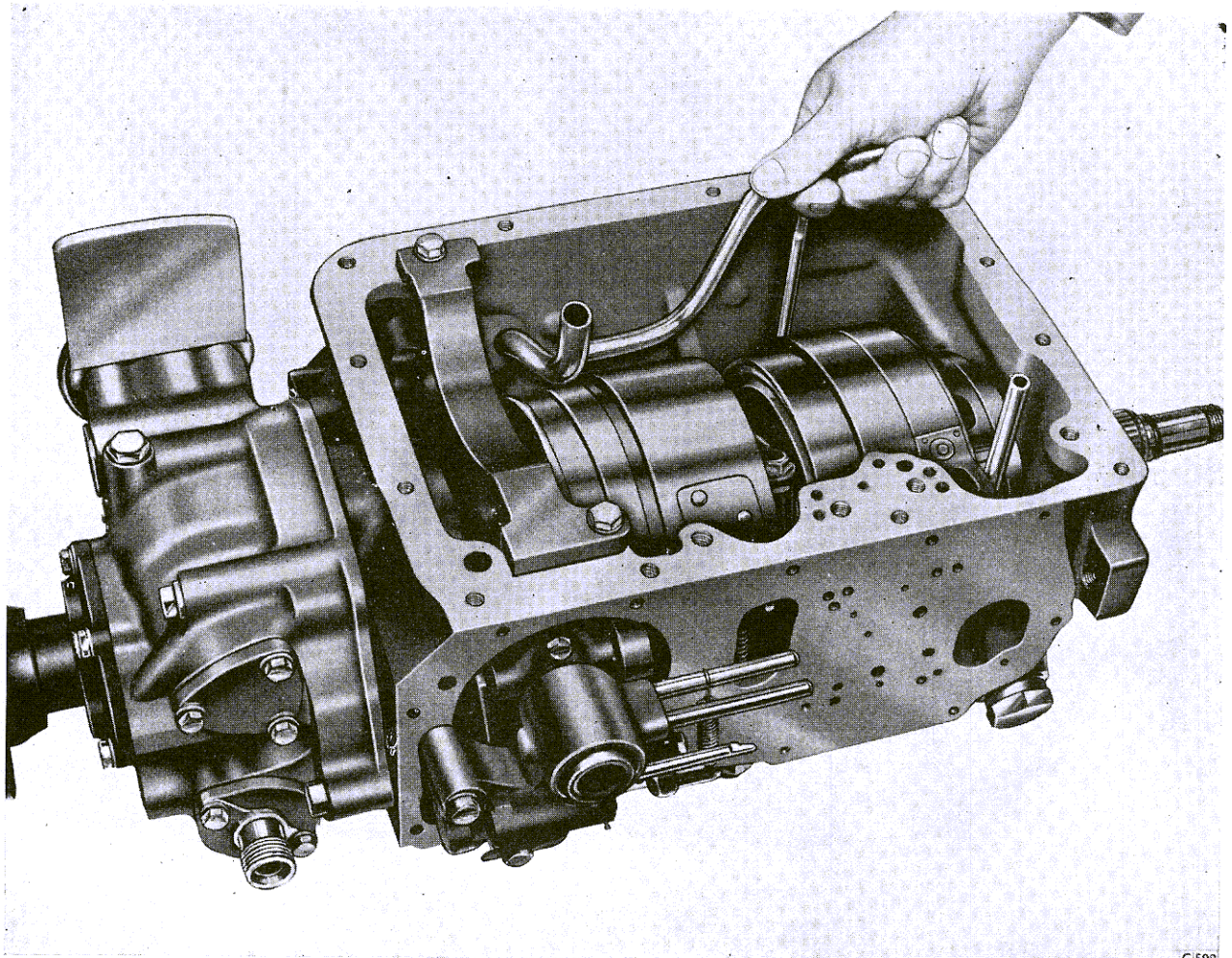

Fig. 69 Removing pump-to-front servo oil pipe

ROLLS-ROYCE AUTOMATIC GEARBOX

Rear pump and governor — To remove

Withdraw the pump-to-front servo oil pipe as shown in Figure 69.

Rotate the output shaft until the large (G1) governor weight faces toward the front of the gearbox. Unscrew the two retaining setscrews and withdraw the pump and governor assembly from the gearbox, as shown in Figure 70.

Rear pump and governor — To dismantle

Dismantling of the governor and rear pump is limited to that described in the following paragraphs.

If wear or damage should necessitate the renewal of a part not covered by these dismantling instructions, either the pump or governor must be renewed as a unit.

When renewing a pump, the bronze driving gear on the output shaft must be examined for wear; if wear is considered excessive or the gears are noisy on a subsequent road test, renew the gear.

Governor — To dismantle

The only parts which can be removed from the governor assembly are the oil sealing rings, the G2 valve and sleeve and a hardened steel washer which is situated in the bottom of the G2 valve sleeve bore; this washer is not fitted on early gearboxes.

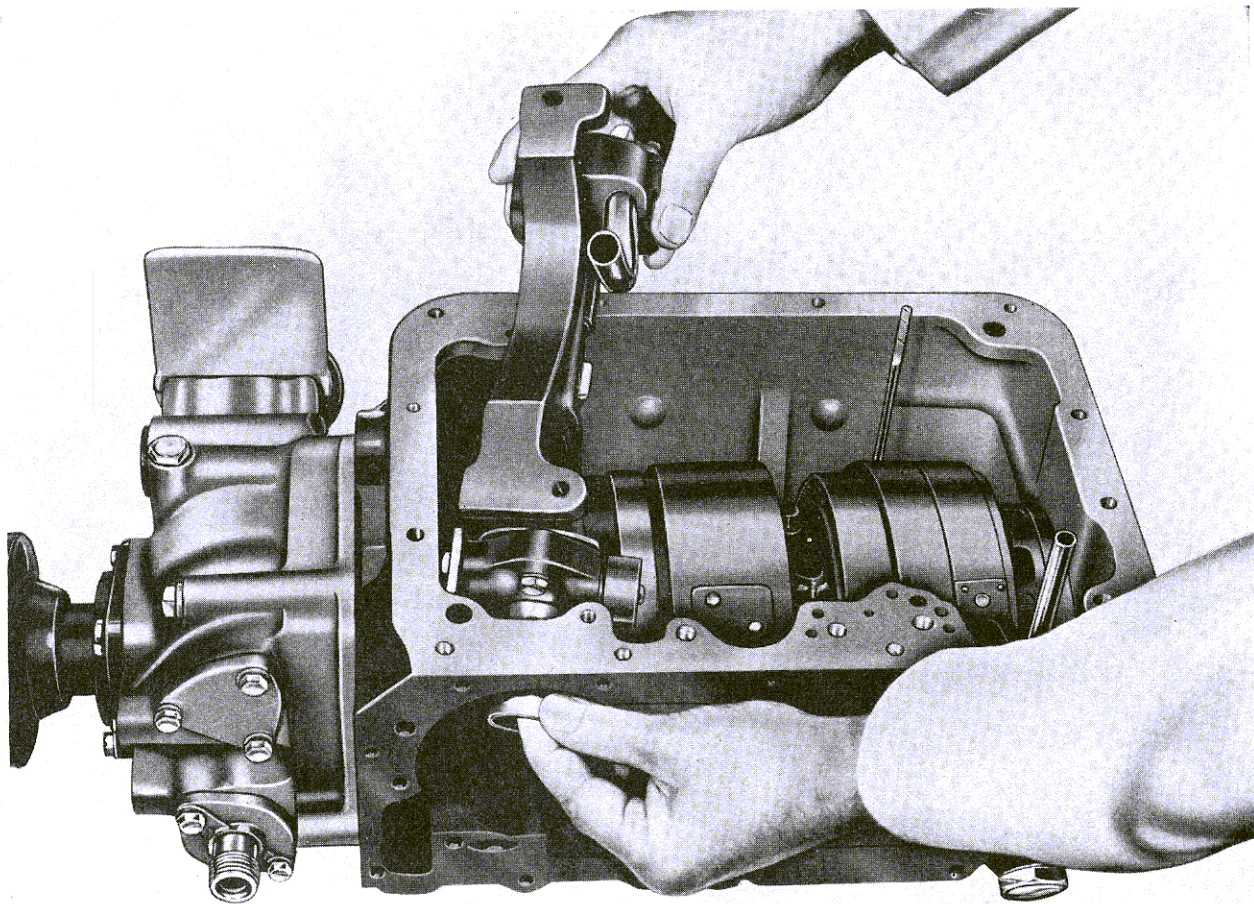

C597

Fig. 70 Removing rear pump and governor

ROLLS-ROYCE AUTOMATIC GEARBOX

The G2 valve can be withdrawn from its sleeve after removing the retaining plate, as shown in Figure 71, but the oil sealing rings need not be removed unless they are worn or damaged.

If a G2 valve is unserviceable, a new G2 valve and sleeve assembly may be fitted, but if a G1 valve is unserviceable a new governor assembly must be fitted as neither G1 nor G2 weights should be removed.

Rear pump — To dismantle

Unscrew the four screws retaining the cover and lift off the pump cover. Withdraw the annulus gear by tilting the pump and gently shaking until the gear drops into the palm of the hand.

Rear pump and governor — To inspect

Clean all the components thoroughly, flush out the oilways with a suitable cleaning fluid and blow through with compressed air. Examine all parts for cracks and burrs.

Governor — To inspect

Check the mating faces of the governor and driving flange with engineers' blue; if either face is distorted, renew the complete assembly as the surfaces must not be scraped. Some early rear pumps are fitted with an aluminium drive flange and in this case both rear pump and governor should be renewed.

Wear of the governor tower is unlikely, but if signs of rubbing are evident, it should be inspected in conjunction with the bore of the parking brake bracket. Wear of this nature is usually caused by the tower running eccentrically. Details of the run-out check and methods of rectification are given under 'Governor — To fit.'

Check the oil seal rings for freedom or excessive clearance in their grooves; if the periphery of a ring appears to be worn, remove the ring, insert it into the bore of the parking brake bracket and check that the ring gap is within the limits given in the 'Summary of Repair Data' at the beginning of this Chapter.

Ensure that the G1 and G2 valves operate freely; they should be heard moving as the governor assembly is gently shaken from side to side.

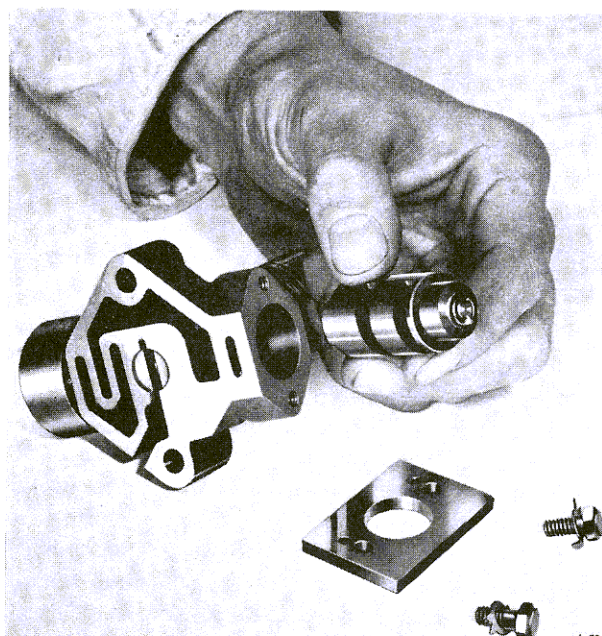

Fig. 71 Removing G2 valve and sleeve

Rear pump — To inspect

Check the governor driving flange and flexible drive retaining pins for security. Failure of the flexible drive is most unlikely, therefore the large amount of axial movement and the small radial movement between the steel driven gear and the flexible drive can be considered normal.

Early rear pumps are not fitted with a flexible drive, the oil pump skew gear being secured to the pump drive shaft by a pin. On some rear pumps the skew gear retaining pin is a sliding fit in the drive-shaft, but an interference fit in the gear. This allows the skew gear to move very slightly radially on the shaft and, providing this slight movement does not suggest that the pin has worn, the pump unit need not be renewed.

Check the mating faces of the pump cover and the pump body with engineers' blue. Small burrs may be removed, but the joint faces **must not be scraped or lapped** otherwise the machining marks may easily be eliminated.

Examine the annulus gear pocket and the pump cover for wear. If scoring in the pocket is severe and likely to affect the pump performance, renew the pump. If the oil pressure is found to be low during fault diagnosis tests, this should be used as a guide when assessing score damage.

ROLLS-ROYCE AUTOMATIC GEARBOX

Inspect the gears for worn or damaged teeth and check the oil inlet pipe for security in the pump body.

Check the inside face of the crescent shaped segment for signs of fouling by the inner gear teeth. If scoring is heavy this is an indication of excessive wear in the drive-shaft bushes; in each case the pump should be renewed.

Rear pump and governor — To assemble

To assemble the rear pump and governor, reverse the procedure for dismantling ensuring that each part is lubricated with clean gearbox oil before being refitted.

The importance of cleanliness is emphasised, but rag should never be used owing to the danger of fluff entering the control system and fouling the valves. Attention is drawn to the special instructions contained in the introductory notes at the beginning of this Chapter, also the torque loading data and schedule of fits and clearances given in the 'Summary of Repair Data'.

Governor — To assemble

Refit the oil sealing rings to the governor tower, using the special tool as shown in Figure 72; if the rings are new, check the gaps by inserting the rings into the bore of the parking brake bracket, then check the clearance in the grooves of the tower.

Insert the steel washer (if fitted), G2 valve and sleeve into the governor body ensuring that the small recess

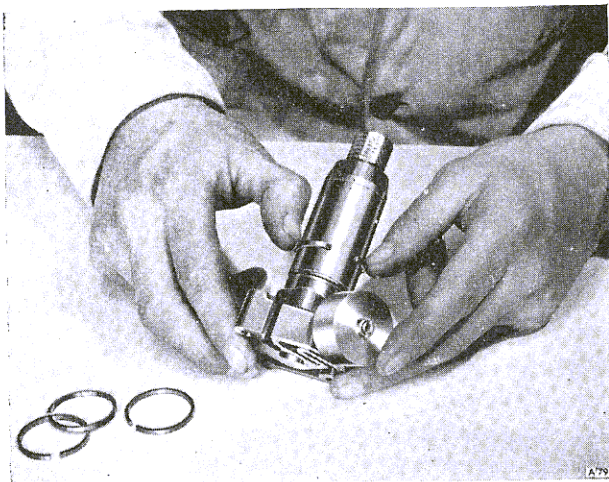

Fig. 72 Fitting governor oil sealing rings

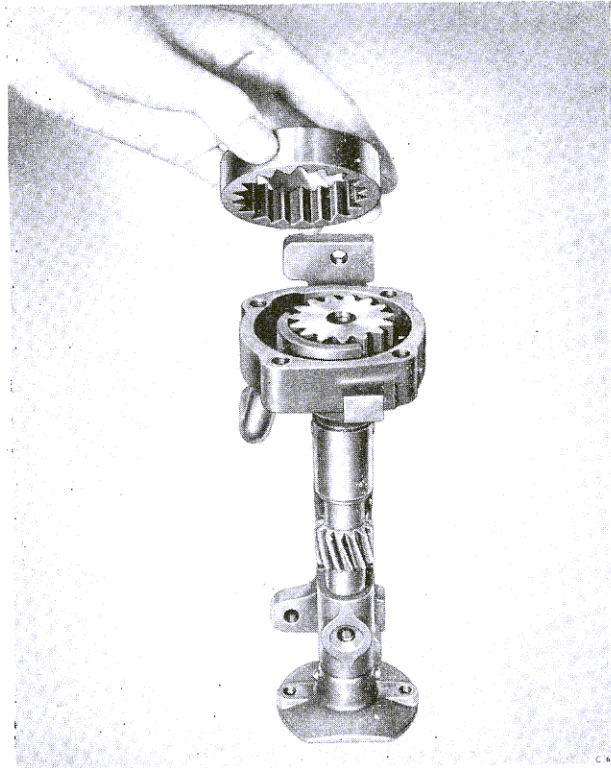

Fig. 73 Fitting annular gear

in the sleeve aligns with the slightly larger recess in the governor body. Refit the retaining plate, ensuring that the dowel in the plate lines up with the two recesses previously described. Fit the two setscrews and new tab washers; tighten the setscrews to the correct torque given in the 'Summary of Repair Data' and lock the tab washers.

Rear pump — To assemble

Assemble the rear pump reversing the procedure for dismantling noting the following points.

Ensure that the annular gear is correctly fitted with the chamfered edge toward the bottom of the annulus gear pocket as shown in Figure 73. Fit the pump cover and the four setscrews; torque tighten to the figure given in the 'Summary of Repair Data'.

Check that the drive-shaft end float is not less than 0.0005 in. or more than 0.0025 in. Pour some clean gearbox oil through the pump intake pipe then turn the gears to check for free rotation.

ROLLS-ROYCE AUTOMATIC GEARBOX

Governor — To fit

Before fitting the governor body to the driving flange it must be checked for swash, using a dial test indicator as shown in Figure 74. Turn the pump shaft several times and check that the swash, if any, is within the limits given in the 'Summary of Repair Data'. If outside these limits, renew the pump and again check for swash.

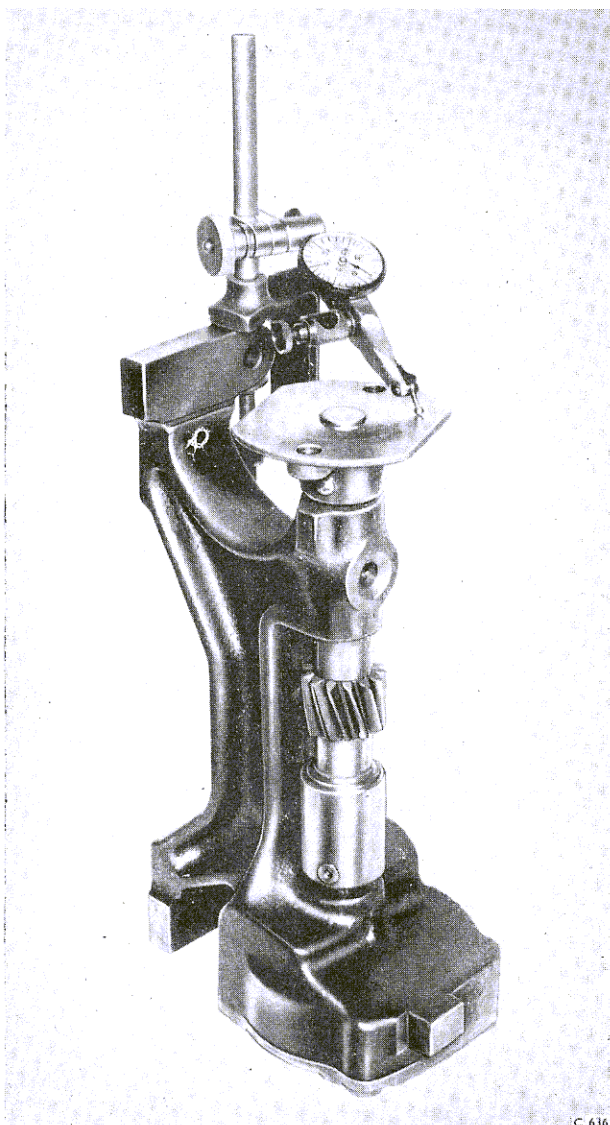

Fig. 74 Checking rear pump flange for swash

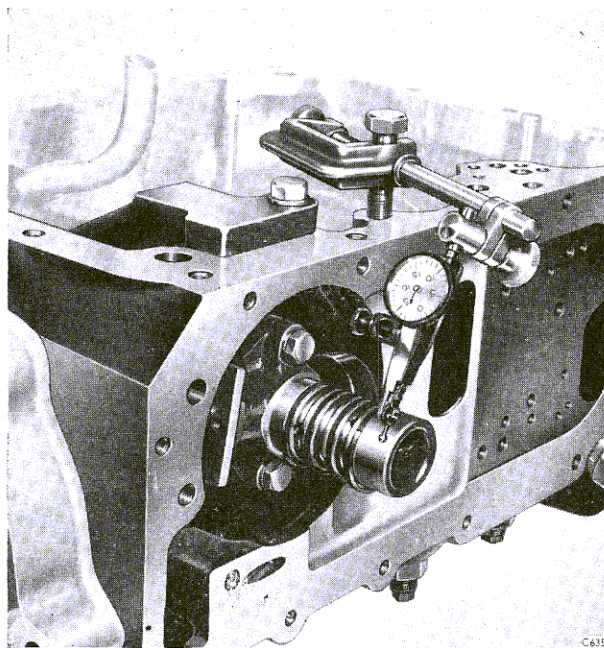

Fig. 75 Checking governor tower run-out

Mount the governor onto the driving flange and if neither of the units have been renewed, ensure that the correlation marks coincide; if a new unit is being fitted, it should be marked after the run-out check described later. Refit the two setscrews and tighten to the correct torque loading. Using a dial test indicator as shown in Figure 75, check the run-out of the governor tower as follows.

With the stem of the indicator contacting the tower approximately 0.250 in. from its outer end, rotate the shaft several times. If the total run-out exceeds the limits given in the Summary, remove the governor from its drive flange, turn it through 180 degrees and refit, then check again. If run-out is still excessive, fit a new governor and repeat the check. If this does not bring the run-out within the limits, the rear pump and the governor must be renewed.

After completing the check, again scribe the correlation marks on the governor and driving flange; refit the parking brake bracket (see Section 5), the control valve unit (see Section 4), the side cover and sump (see Section 3) then refill the gearbox with oil. Prime the ride control unit if fitted.

ROLLS-ROYCE AUTOMATIC GEARBOX

Rear pump and governor — To fit

When both the rear pump and governor have been removed from the gearbox, the assembling and checking procedure is similar to that given under 'Governor — To fit'. It is, however, easier to check for swash and run-out before installing the combined assembly into the gearbox; in such cases the dial test indicator should be mounted onto the pump body.

After completing the checks, ensure that the mating surfaces of the gearbox and pump unit are free from burrs, especially around the setscrew holes, then, with the G1 weight facing the front of the gearbox fit the assembly, at the same time slightly rotating the governor to mesh the gears. Fit the two retaining set-

screws to the correct torque loading.

Refit the front and rear servo units (see Section 6), parking brake bracket (see Section 5), control valve unit (see Section 4) and side cover and sump (see Section 3). Fill with oil and prime the ride control unit if fitted.

Serviceability check

After overhaul or fault rectification, a road test should be carried out to ensure that the gearbox functions correctly, particular attention being paid to that part of the test which led to the diagnosis of the fault. Details of the tests concerned are given in Chapter 2.