

# TEE ONE TOPICS

---

---

Number 38

August 2004

## DELVING

This is what you will find if you get very serious about burrowing into your vee eight engine. Nowadays the most difficult task is getting the cylinder heads off the block since with the various electrolytic activities going on around the studs the heads are effectively glued on. The camshaft seen at the bottom

of the trough needs to be examined very carefully for wear particularly the cams driving the hydraulic pumps on Shadow engines. The tappet blocks can be clearly seen minus their tappets and the rearmost block has been removed for some reason. At the very back of the trough is a baffle which identifies the engine as a pre-Shadow unit. The baffle covered a vent at the back of the block which allowed fumes to exit via a

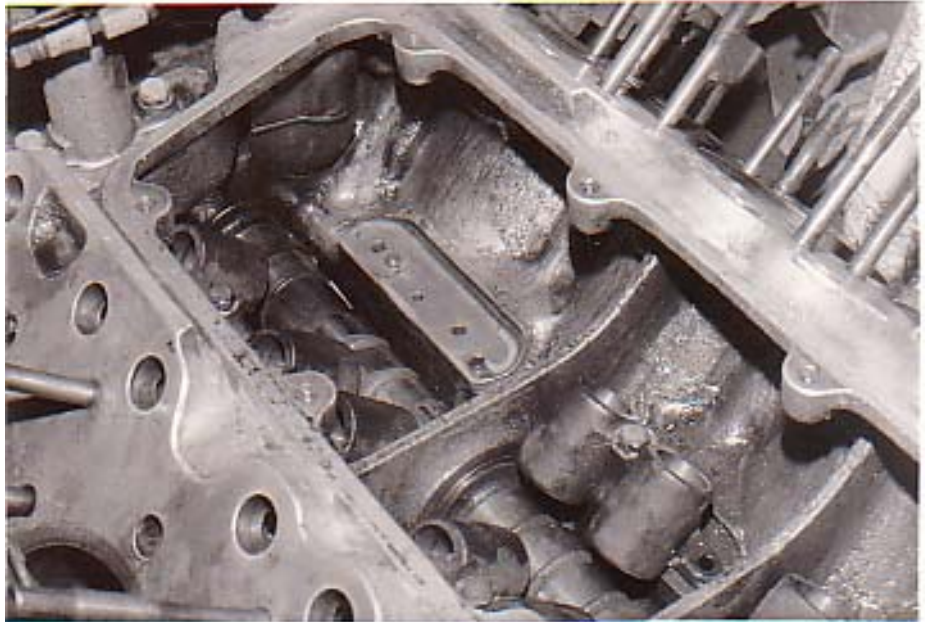

tube that emptied under the car. If the baffle was not correctly fitted the spinning camshaft will fire a steady stream of oil up behind the baffle which will then give you a well protected rust free chassis from the back of the engine aft! The solution is to pull the valley cover and carefully bend the baffle to a tight fit against the rear of the block.



## MIND BLOWING STATISTICS

*My son sent me this gem from the internet. Drag racing has always defeated my understanding of some members of the human race but it obviously has an appreciable following. Rolls-Royce for most of its life would never quote developed horsepower considering it, I understand, vulgar. Reading the following persuades me to agree with the policy. But boggle we surely must at these figures.*

One Top Fuel dragster 500 cubic inch Hemi engine makes more horsepower than the first 4 rows at the Daytona 500.

Under full throttle, a dragster engine consumes 1-1/2 gallons of nitro methane per second; a fully loaded 747 consumes jet fuel at the same rate with 25% less energy being produced. A stock Dodge Hemi V8 engine cannot produce enough power to drive the dragster supercharger.

With 3000 CFM (cubic feet per minute) of air being rammed in by the supercharger on overdrive, the fuel mixture is compressed into a near-solid form before ignition. Cylinders run on the verge of hydraulic lock at full throttle.

At the stoichiometric (stoichiometry: methodology and technology by which quantities of reactants and products in chemical reactions are determined) 1.7:1 air/fuel mixture for nitro methane the flame front temperature measures 7050 degrees Fahrenheit. Nitro methane burns yellow. The spectacular white flame seen above the stacks at night is raw burning hydrogen, dissociated from atmospheric water vapour by the searing exhaust gases. Dual magnetos supply 44 amps to each spark plug. This is the output of an arc welder in each cylinder.

Spark plug electrodes are totally consumed during a pass. After 1/2 way, the engine is dieseling from compression plus the glow of exhaust valves at 1400 degrees F. The engine can only be shut down by cutting the fuel flow.

If spark momentarily fails early in the run, unburned nitro builds up in the affected cylinders and then explodes with sufficient force to blow cylinder heads off the block in pieces or split the block in half. In order to exceed 300 mph in 4.5 seconds dragsters must accelerate an average of over 4g. In order to reach 200 mph well before half-track, the launch acceleration approaches 8g. Dragsters reach over 300 miles per hour before you have completed reading this sentence. Top Fuel Engines turn approximately 540 revolutions from light to light! Including the burnout the engine must only survive 900 revolutions under load. The redline is actually quite high at 9500rpm.

The Bottom Line; Assuming all the equipment is paid off, the crew worked for free, and for once NOTHING BLOWS UP, each run costs an estimated \$1,000.00 per second. The current Top Fuel dragster elapsed time record is 4.441 seconds for the quarter mile (10/05/03, Tony Schumacher). The top speed record is 333.00 mph. (533 km/h) as measured over the last 66' of the run (09/28/03 Doug Kalitta).

Putting all of this into perspective: You are driving the average \$140,000 Lingenfelter "twin-turbo" powered Corvette. Over a mile up the road, a Top Fuel dragster is staged and ready to launch down a quarter mile strip as you pass. You have the advantage of a flying start. You run the 'Vette hard up through the gears and blast across the starting line and past the dragster at an honest 200 mph. The 'tree' goes green for both of you at that moment. The dragster launches and starts after you. You keep your foot down hard, but you hear an incredibly brutal whine that sears your eardrums and within 3 seconds the dragster catches and passes you. He beats you to the finish line, a quarter mile away from where you just passed him.

From a standing start, the dragster had spotted you 200mph and not only caught, but nearly blasted you off the road when he passed you within a mere 1320 foot long race course.



## WARWICK'S TRUSSES

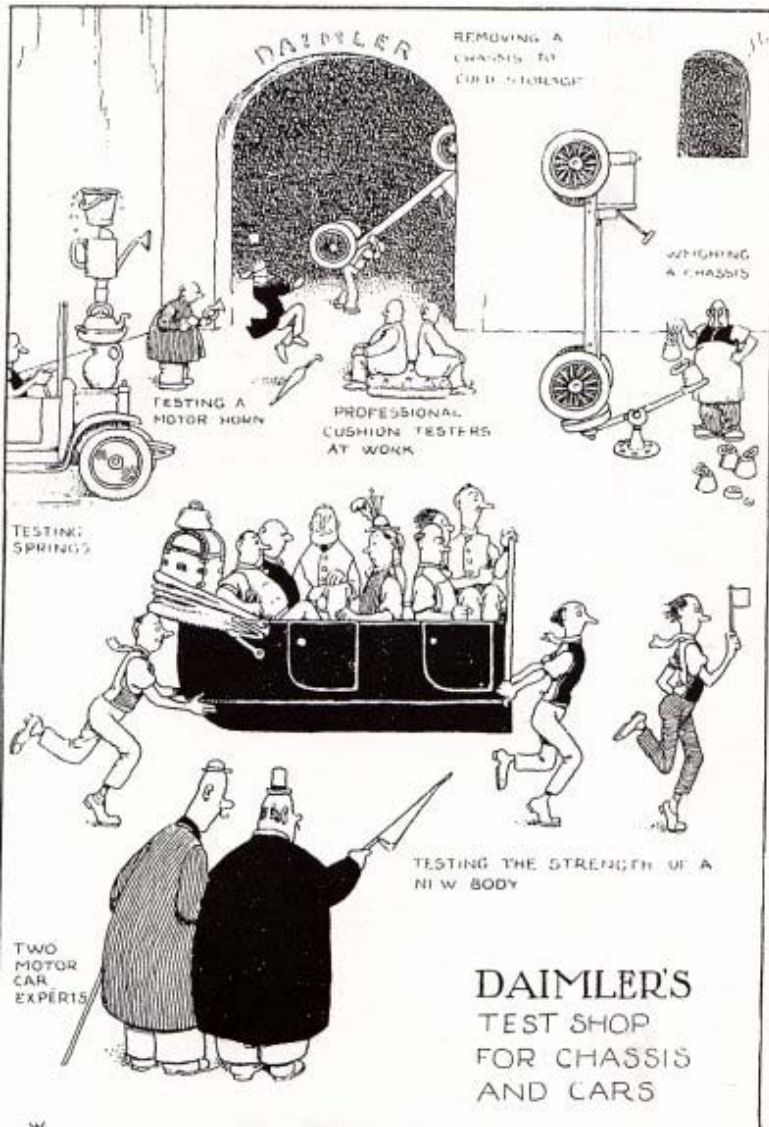

would not go astray.

In the 1930s William Heath Robinson (1872 -1944) was known as "The Gadget King" and he is still most widely remembered for his wonderful humorous drawings. At the time of his death in 1944 only a minority of his public remembered his work as a serious illustrator. He was unusually prolific, with a seemingly inexhaustible stock of good ideas. The basis of his humour was human nature, and so the majority of his work seems as fresh and relevant today as when it was first published. Personally I rather enjoy one of his more famous quotations "I really have a secret satisfaction in being considered rather mad." One of his many many works followed a visit to the Daimler factory which I include here. But more to the point I found this wonderful Silver Shadow Truss Warwick designed to suspend his long wheel base car while the wheels were being titivated.

I hasten to add that as far as I am aware Warwick needs no intestinal augmentation but he has designed some of the more interesting pieces to assist in maintaining our vehicles. One of the more innovative items was designed to remove the hub caps peculiar to long wheel based post-war cars up to 1987.. These can be very tight to spring off usually resulting in damaged paintwork on the wheel and the item frisbeeing across the yard when it was eventually detached with a loud bang. Warwick's device consisted of a lever with projection, the combination although designed for hub caps however could probably be employed for the possible removal of one of the propellers from the Titanic.

Alert readers will have seen the feature that probably prevented the device from going into production and that was the need to tow a small trailer for its conveyance! Several times I have endeavoured to insult Warwick's genius by quoting a very famous artist and cartoonist who died during the last World War – W Heath Robinson. This lamentably has brought blank stares from the younger among us (i.e. under 60) so I thought a little reference here



And it is not inappropriate to warn every one of you that if you are going to lift a car off of its wheels, do so with great care. Never sit cars on bricks, concrete blocks or rocks – they collapse. Use good quality heavy jack stands that not only handle the weight with ease but also have lateral stability. And never crawl under a car resting solely on a jack!



### **TIP FROM AN AMATEUR**

If you have a lot of bolts and nuts to undo to remove an assembly, always do the most inaccessible ones first. While you are fresh and enthusiastic is when the most difficult and intransigent bolt should be tackled. When you are tired, boxes of matches, buckets of petrol and sledge hammers become very appealing!

## **THE MYSTERY OF THREADS**

*Originally written by Charles Falco for the American motorcycle enthusiast. The text has been modified to make it more relevant for the Australian British car restorer. The Factory used BSF and a little Whitworth up to the end of production of the Silver Dawn R type. Production of the Spirits however saw lots of metric creeping in as sub-contractors changed their machines to the new dimensions. This is particularly evident in steering mechanisms.*

First, a tiny bit of history. In the 19th Century every British factory which needed to bolt something to something else devised their own fasteners to do it. Clearly, this caused all sorts of compatibility problems. So, along came Mr. Whitworth (I forget his first name right now) who invented a standardized system of coarse threads (with 55-degree thread angle and rounded roots and crests). This standardization was a Good Thing. Along with his threads came heads for the bolts that were based on the length along: the side of one flat, rather than across the flats. Hence, there is no simple fractional number for the length across the flats, which is why your imperial spanners don't fit. The fractional number on your spanners refers to the diameter of the bolt which is 1/4", 3/8" etc. not the distance across the flats (which ends up being various weird dimensions). Some years later the British decided

they needed a finer pitch for some applications, so another thread series was introduced (same 55 degree angle). They also decided that the heads were too big for the bolts, so for most applications they switched to using the next size smaller heads. Because of this, and to add one more bit of confusion to life, one manufacturer will mark a particular spanner "3/8BS," while a different manufacturer will mark the same sized spanner "7/16W." They fit the same diameter bolt. The first thing any fledgling British car restorer learns is that his (or her) car has "Whitworth bolts." They think this is interesting, buy a set of "Whitworth spanners," discover these spanners fit their bolts, and believe they now know everything they need to know about British fasteners. Unfortunately, at this point they know only enough to make themselves dangerous. Instead, what they should have said to themselves is "Oh my God, what other weird and incomprehensible things have they done to the fasteners on my machine?" The answer to this question is:

**British Standard Whitworth (BSW)** These are the original, 19th Century, coarse-threaded industrial bolts designed to hold locomotives together. Because of their coarse pitch, they are more prone to vibrating loose, so are little used on motorcars. Except for threading into aluminum (e.g. crankcase studs), where a coarse thread is less prone to stripping than a fine one. It turns out that, except for 1/2" (where the British use 12 threads per inch (tpi) and Americans use 13 tpi) the thread pitches for the rest are the same as for American Unified Coarse (UNC). However, the thread form is different; Whitworth = 55 degrees; UNC = 60 degrees. In spite of this, mismatched nuts and bolts mate nicely, so you're likely to find UNC bolts or studs where BSW should have been:

**British Standard Fine (BSF)** A finer pitch series, analogous to the American Unified Fine (UNF), although - unlike the case of BSW/UNC - with none of the pitches in common with UNF. Many motorcar and motorcycle manufacturers commonly used a lot of BSF threads.

**Cycle Engineers' Institute (CEI) or British Standard Cycle (BSC)** These are different names commonly used for the same threads. 60 degree thread angle, rather than the 55 degree of BSW and BSF. For sizes from 1/4" through 1/2" by far the most common are 26 tpi, although 24 tpi appear as well. Most, but by no means all, fasteners on post-War BSA's (through the late '60's, when it got more complicated) were CEI. Although the thread form and pitch is different, the head sizes on CBI-threaded fasteners use the same wrenches as BSW/BSF.

**British Association (BA)** 47-1/2 degree thread angle. This is a metric thread system devised by the British for small screws used in components like speedos. Not metric like you might expect, but with diameters determined by a factor proportional to a power of the logarithm to the base 10 of the thread pitch in millimeters. I couldn't possibly be making this up. Ah, the English. You'll find lots of BA threads on any British car, but only for fasteners smaller than 1/4". BA fasteners have their own set of spanner sizes. Typically, a set of "Whitworth" sockets will include a OBA (and maybe a 2BA--bigger number = smaller size) socket.

**British Standard Pipe (BSP)** A tapered, self-sealing thread system used to seal fluids (interestingly, the US and the metric world standardized on the BSP system for threading all their pipes). Unified Fine (UNF) and Unified Coarse (UNC). In the late 1960's, when even the U.S. was thinking of going metric, the giant BSA corporation decided it was finally time to scrap that old 19th Century Whitworth-based system, and switch to....yes, you guessed it, American. Since they had lots of money invested in tooling, the switch wasn't made suddenly (or completely), so bikes and cars from the late '60's and later had a mix of all sorts of thread forms. Typically, engine internals (e.g. the thread on the end of a

camshaft) stayed with whatever form it used to have, while simple fasteners (e.g. holding the mud guards on) switched to UNF.

**"None of the Above"** While the above systems account for well over 95% of all threads you'll ever run across on a British machine, some manufacturers--again BSA springs to mind, but others were guilty as well-- couldn't restrain themselves from inventing a few oddball pitches of their own. This is why, when dealing with British cars, you should assume nothing. You must have a pitch gauge and calipers. So, let's get back to the question someone asked a few days ago about buying a set of "Whitworth" taps and dies to last him the rest of his British car life.

The first thing I'd say is that if you want it to last, be sure you buy a HSS set (rather than carbon steel), even though it will be at least twice the price. Then, in order of overall usefulness, I believe you'll find in first place it will be a CEI/BSC set, then BSF, and then BA. Unless/until you really get deeply involved, make do with UNC to "simulate" BSW (although you'll want to buy an individual 1/2"-12 at some point to supplement the UNC set). Thus, if you follow my recommendation, the very last thing you'll want to buy for working on your British machinery is a "Whitworth" set.



## PUT YOUR FOOT DOWN AND WHAT DO YOU FEEL?

All of us know that applying the brakes in a post Cloud car simply requires opening the

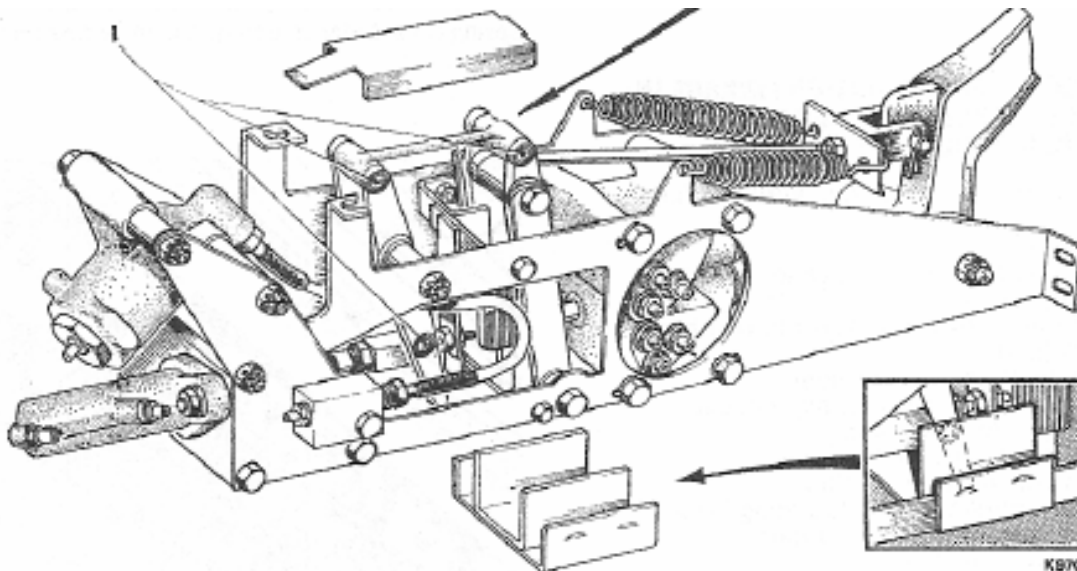

The well known 'Rat trap' which is bolted under the floor beneath the driver. This example is fitted with the master cylinder which is the bit poking out at the lower left of the drawing. The bit floating above the whole assembly has a 'funny' story to it. The spin merchants having exhausted themselves on the 'triplicated' braking systems must have been horrified to learn that it was possible on the very very early cars for the pin connecting the pedal to the whole system could actually fall out giving nil brakes! The floating bit was devised to ensure this did not happen.

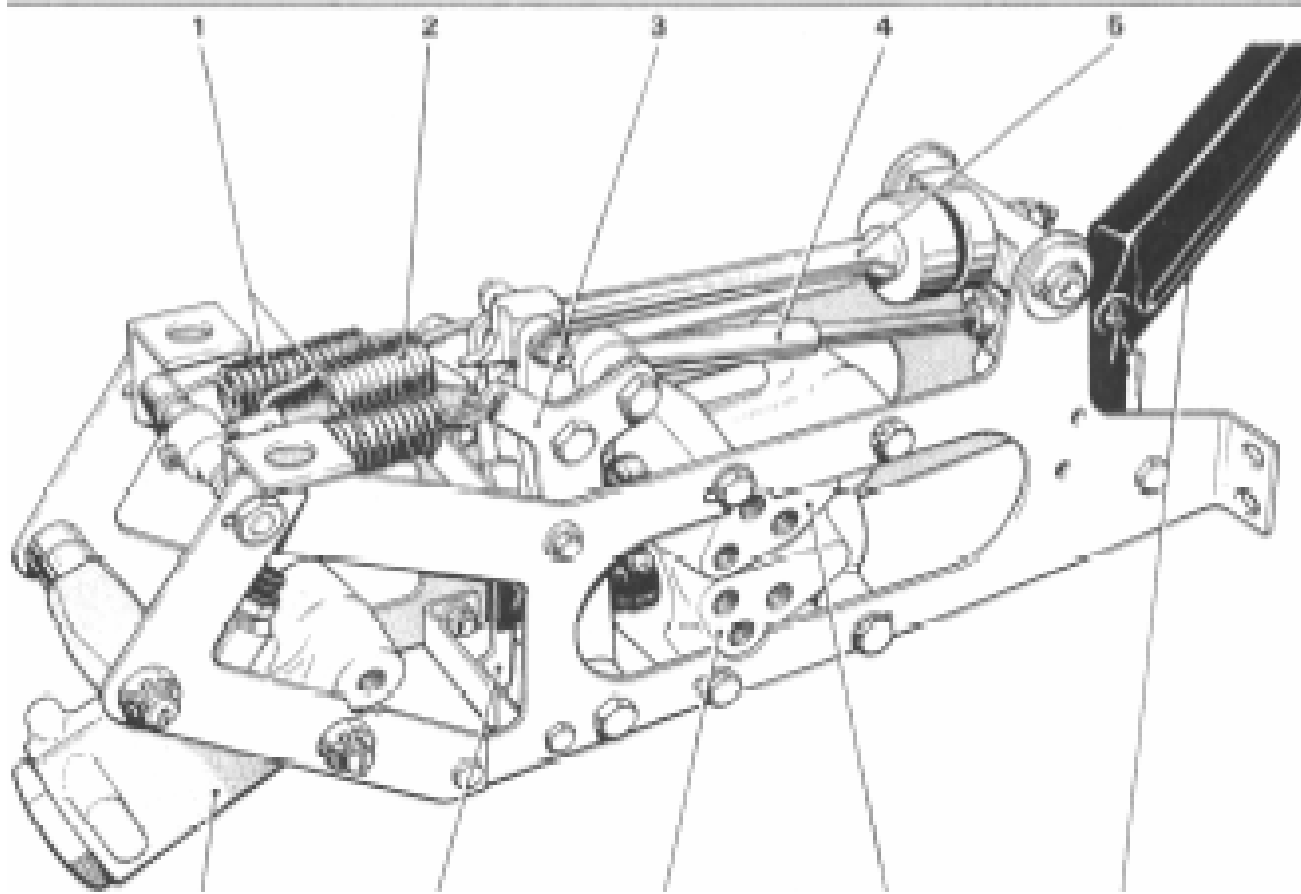

And this is the no-master cylinder version. The round protuberance at the bottom left is still the deceleration valve to help stop the rear wheels skidding during a frantic halt, and item 5 is the rod that has, at the right hand end, the conical rubber attached to jam into the adjacent cup giving your foot an encouraging feel

tap to the accumulators and let the built up pressure rush out to the callipers and stop those discs. But turning taps on doesn't require more than token pressure which is good in the kitchen otherwise you would finish up with very sore wrists. When Citroen first fitted this system to their cars they decided to dispense with the

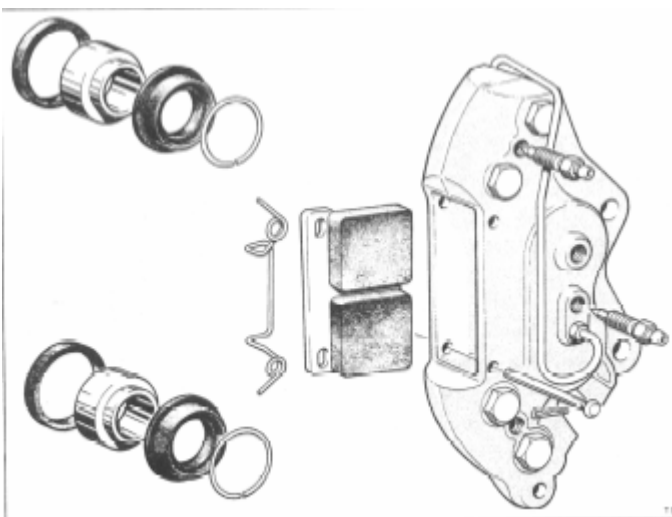

conventional brake pedal and in lieu fitted a button in lieu somewhat reminiscent of a floor dipper switch. This apparently worked perfectly, the driver was able to apply just enough pressure to the 'button' to achieve the amount of braking

One of the rear callipers showing the two bleed nipples for the upper and lower pistons. Although after market brake pads are available for the front callipers, the rear ones are an RR special. Do be sure to fit anti-rattle springs one of which is shown here.

required. But habits die hard and new owners simply couldn't believe that they could stop without being able to lay the boot into a substantial pedal.

Rolls-Royce picked up on this reaction and provided a brake pedal from the outset with the Shadow installation. But they also realised that there had to be some sort of graduated resistance to the depression of the pedal proportional to the braking effort being exerted. So, from the beginning of the series a very small master cylinder apparently pinched from the old Morris Minor, was inserted into the rattrap under the floor and it was this that the driver pushed against to give him pedal feel as the brakes were applied. The spin merchants of course leapt on the fitting as a 'third braking system' although its actual ability to halt the progress of the car ranked with the legendary foot out of the door.

About mid 1975 (chassis approx late 21000), the master cylinder was dispensed with and in lieu the pedal mechanism in the rattrap jammed a conical rubber moulding into a suitably receptive metal aperture. This gives the pedal ample 'feel' which is progressive and dispenses with the complication of a small hydraulic system with all the attendant maintenance that attracts. The master cylinder system operated pistons in the rear calliper. Very early cars ( in the approx <2000 series chassis) were plumbed for the master cylinder to operate the rear upper calliper piston, the high pressure system operated the lower one. Subsequently these were reversed. Bleeding the master cylinder circuit if you have one was covered in detail in the last issue of Topics.



### TIPS FROM AN AMATEUR

Have plenty of empty containers in your workshop. Buy a heap of take away plastic items with lids that can be labelled and stacked. Have on hand a variety of self sealing plastic bags to store components.



### MYSTERY PHOTO

You would be forgiven for not working out the subject here – I was. Taken years ago during the rebuild of my old Silver Dawn SDB94 which has now disappeared. The picture is taken of the front axle centrally through the mount that guides the much-loved crank handle to the crankshaft boss. The bolt passes through a very strong cradle that not only carries the radiator core but also provides an anchor for the valance plates either side of the engine. It is on the latter that the mudguards bolt and they in turn take the weight of the bonnets. And the whole lot sit on that solitary large bolt seen in the centre of the axle.

The bolt in turn passes through a silent bloc bush mounted on the front cross member erroneously called the front axle. The latter carries the suspension





and is subjected to very vigorous twisting and percussive loads. By carrying the front end of the car body on the one bolt the chassis can make a merry dance before it disturbs the panels. By contrast my Armstrong Siddeley has the radiator frame mounted on the cross member at either side and on a rough road the gyrations of the bonnet and fenders is something to be wondered at!

The Rolls-Royce design has a further facility. The grille however impressive can be very difficult to fit and finish up with even gaps in the right place. Owners trying to achieve this often forget that the mount through which the large bolt passes is itself bolted to the cross member in four places and the holes through which the bolts pass are slotted. If these are left loose while all the panels are bolted up to the installed grille you have a good chance of achieving a perfect fit. But don't forget to tighten them afterwards.

## **SELF HELP DAY AUGUST**

A very tidy group turned up for breakfast on Saturday 7 August . The topic was hydraulic flushing on Shadows. Now that I use LHM in the Blue Beast I stand askance at the effort that has to be put in to the maintenance of these systems. It seems that changing the fluid annually is mandatory given the rate of deterioration of the stuff. The fluid is almost clear in colour so at the first sign of discolouration, flush it out with clean stuff. The following pictures taken by my mate Peter give some idea of the industry and appetites for the day.



Assembled in my brand new garage and regaled by George Shores out of sight from left were Kevin Findlow a new face and car from Cooma, Bill Fleming, Ken Baldwin, Bob Campbell-Stewart Garry Scorgie and Ken Lo (both out of sight) Kerry Bos, Warwick Grigg and Alistair Kinloch. All except Ken Baldwin are Shadow owners.



I think I recognise Warwick Grigg's dirty thumbnail but the brake fluid in the collecting jar pulled out of Yass member Garry Scorgie's car would frighten the average pathologist. We all know that the fluid is hygroscopic but I was startled to read that in tropical areas it can take in as much as 10% by volume of water. This is great stuff for those intricate bits in our brake and suspension systems.

## **STEEL LINERS IN AN ALUMINIUM BLOCK**



On the previous page a view of the cylinder liners in a pre-Shadow car. A keen eye will notice that there is clearance around the studs where they pass into the cylinder block. The studs actually go very deep into the aluminium casting before they pick up their threaded anchors. All the threads in these engines are Helicoiled with stainless steel so that in the event of a thread failing the coils can be removed and replaced.

Wet sleeve liners are not new even when this engine was built. To remove them is complex involving heating the block to an untouchable level then pulling the liners one by one with a suitable plate and screw. Unfortunately with corrosion, deposits build up at the bottom of the liner and injudicious pulling can easily crack the block. Even with this difficulty however it is a good idea to clamp the liners in position once the heads are off to ensure they do not move and break the seals at the bottom of the block.



### **TIPS FROM AN AMATEUR**

Do not over tighten wheel nuts. On Rolls-Royce cars the spanner or as our North American friends call it, the 'lug wrench' is designed to give the correct amount of leverage to insure against over tightening. Never allow tyre shops to use air spanners on the brass wheel nuts. They should be hand tightened and loosened. Over tightening will not only distort the tyre rim but will squash the nose of the nut and make it difficult to refit the nut.

### **DIFFERENTIAL WHINE**

There has been a good deal of discussion on the Club site about whining differentials. The general consensus is that the last quiet diff produced by the Factory was on the Cloud. The very large aluminium casing housing the gears allows them to be set up with great precision but then a good hard high speed drive the casing gets hot and where are all your settings? Well that is the theory. I served this up to a former god at the old Factory during the Centenary Rally and he corrected me with the advice that there was a gear cutting angle that was really the problem. This was amazing that they did not manage to correct the problem over some 70,000 cars! Anyway one of my more erudite readers, mindful of old techniques of silencing diffs in used car yards offered the following as a possible Factory Bulletin! Those who have had to follow these epistles will appreciate the satire.

To fit banana skins to the differential , follow the schedule in TSD 6911.

Remove the body  
Dismantle the steering box  
Place the chassis on a vertical stand  
Peel six grade PS6311 bananas, part number UB5053  
Using Mixmaster part number UD 69797 shred the banana skins to a width of 0.7311 inches  
Polarise the banana skins as described in Bulletin A61197  
Remove the final drive drain plug and carefully insert the prepared banana skins  
Reassemble vehicle  
Refill the final drive with olive oil



This process has since been superseded due to the availability of synthetic bananas.



## SHUDDER

Everybody knows that brake hoses for all cars should be replaced at

least every 8 years. The kinky hoses on the preceding page had been fitted by the Factory 34 years ago! The lower ones were made in Canberra by a licensed manufacturer for \$45 each; a small price to pay for peace of mind. And if you thought it couldn't happen to you witness the following pic from Bob Chapman. He had a Silver Spirit up on the jack to check something and said to the owner in the driver's seat "step on the brake" which the owner did with a vengeance. The two hoses connecting the rattrap to rest of the car blew off their fittings! Definitely laundry time I hope you would agree.



## THE WORST NIGHTMARE

About the worst thing that can happen to your car is for the engine to run out of coolant at high speed. Unfortunately low coolant lights and overheat buzzers are usually a signal the damage to your engine has occurred. Even the most assiduous driver doesn't check his lights every few seconds and the presence of a light on the warning panel particularly on a bright sunny day is not the most obvious warning among the many stimuli a driver is subjected to in a modern car at high speed. A buzzer however is hard to ignore although in a crisis identifying where it is coming from is another matter. The overheat buzzer fitted to Shadows from the mid seventies was very effective but with the head heated to over 120 degrees centigrade, damage has more than likely been done.

The Silver Spirits are worse off in that until about 1988 they used a simple overflow tank to keep the system full of coolant. But if say a bottom radiator hose burst at speed the engine would empty in seconds and the coolant in the overflow tank would remain undisturbed which means that the low water sensor would be unaware of the drama beside it and the warning light would not come on. Further the high temperature sensor and buzzer from the Shadow engines was dispensed with on the Spirits.

But help is at hand. A Queensland company has patented a device that is easily fitted to our cars called the 'Engine Saver'. This consists of a slim probe inserted as high as possible in the coolant system, usually in the top radiator hose. This is connected via two wires to an alarm unit discreetly mounted under the dashboard. The instant the coolant level drops below the sensor the alarm sounds. The whole device costs about \$140 and is easily installed by the owner. All the detail can be gleaned from the company's web site [www.enginesaver.com.au](http://www.enginesaver.com.au).



## HOISTING A CAR AND PLACING IT ON JACK STANDS.

It is quite appalling the damage done to the under body of cars by idiots with uncontrolled jacks. The following diagrams should be studied by owners and notice taken of the activities of vandals when they get near the cars.

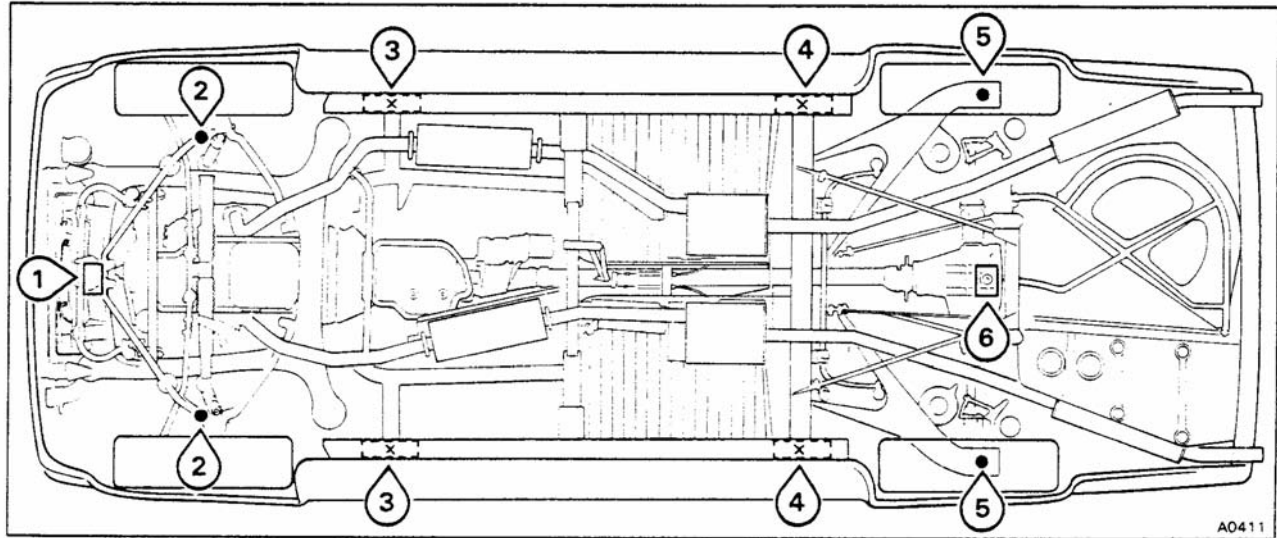
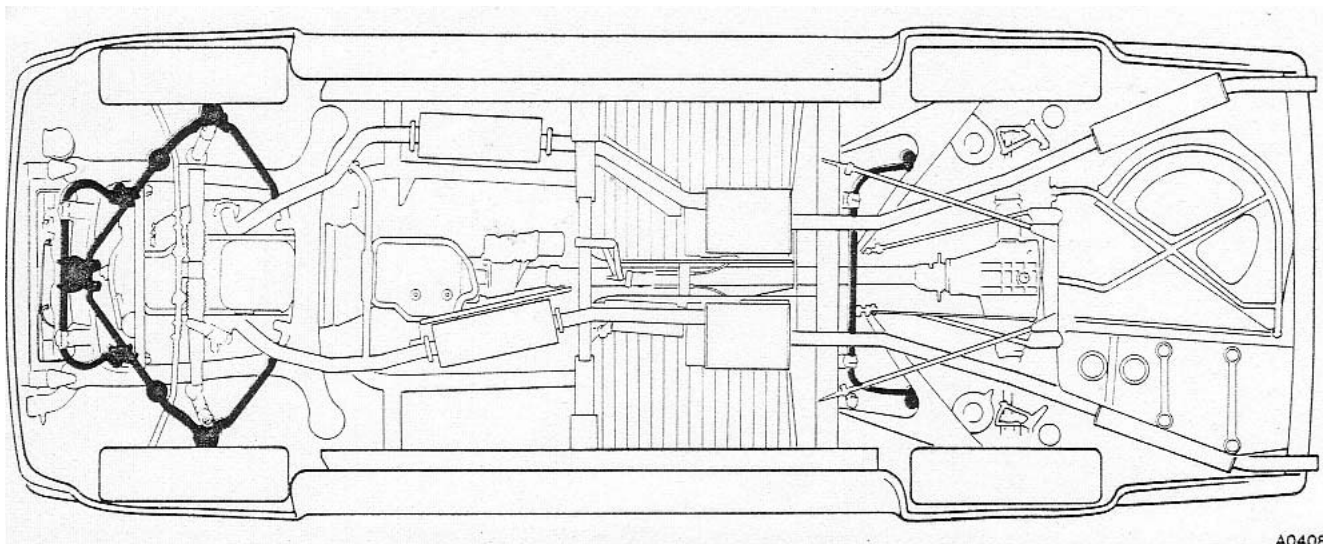

Fig. A7-1 Car jacking positions and support locations

- |   |  |
|---|--|
| 1 Trolley jack positions (front)            | 4 Car jack and sill block positions (rear) |
| 2 Car stands (front)                        | 5 Car stands (rear)                        |
| 3 Car jack and sill block positions (front) | 6 Trolley jack positions (rear)            |

Hopefully you have a trolley jack. Get your local rubber man to cut a 6" square of 1" rubber for you to sit on the head of the jack. This allows the jack to get a better grip on the bits underneath and also prevents damage by scratching etc. And if you have to tie the car down here are the things to lash to!



A0408

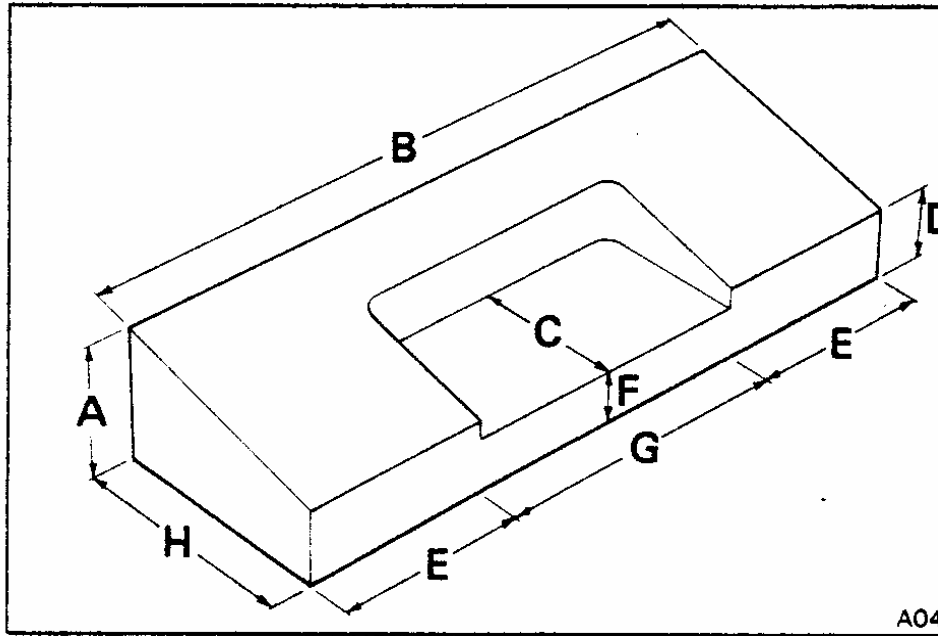

**Fig. A7-3 Hardwood sill block**

A	44,45 mm (1.750 in)
B	228,60 mm (9.0 in)
C	53,98 mm (2.125 in)
D	25,40 mm (1.0 in)
E	63,50 mm (2.50 in)
F	19,05 mm (0.750 in)
G	101,60 mm (4.0 in)
H	79,38 mm (3.125 in)

And of course you have had made up your blocks of wood to put on the heads of your jack stands. If you haven't follow the dimensioned drawing above and have your friendly local carpenter run up four. These can be used on both Shadows and Spirits and really are essential to avoid damage. The cut-out bit accommodates the drain holes in the sills.



## A FEW MORE AMATEUR TIPS

Avoid buying sets of very large spanners and sockets. When you find you do not have a tool to fit measure the 'across the flats' of the nut or bolt and go to your friendly tool place to buy a specific tool. Despair not that you may never use it again – you never know and they are not a large outlay. They are also a great conversation piece. If they buy 'cheap' spanners if they are available and don't be talked into buying very expensive tools unless you are a professional and going to give them a lot of use. In

the remote event of breaking a spanner – simply go and buy another. The essential requirement is that the spanner or socket fits firmly. Cheap spanners and I am not talking about the remainders at Target, if they do not fit can be ground out until they do. Sockets however cannot be easily fitted.

When using brake fluid around and in a car think of the worst scenario and the consequences. From the point of view of paintwork, brake fluid is deadly and we are talking RR363 here. The newer LHM is basically engine oil which is harmless although I would not fry my morning eggs in it. Never pass brake fluid over the fender without the latter being well covered. Topping up reservoirs should be done with cheap plastic funnels with shortened spouts. Lastly always have a bucket of water nearby to douse the paintwork which has had brake fluid spilt on it.

If for a variety of reasons you are unable to flush the RR363 out of your hydraulics, buy in a good stock of the fluid and over several weekends syphon out the reservoir cleaning it thoroughly and refill with clean fluid. Most of the fluid in the system returns to the reservoir in the normal range of usage.



## WEB SITES YOU SHOULD HAVE ON YOUR COMPUTER

<http://www.rroc.org.au/>

Rolls-Royce Owners' Club of Australia

<http://web.rroc.org/>

Rolls-Royce Owners' Club of America

<http://www.swammelstein.nl/rolls.htm>

A Dutch private web site with an excellent forum

All the above sites have free forums where you are welcome to share your knowledge and ask your questions. Or write to me - Bill Coburn Post Office Box 827 FYSHWICK ACT 2609 Australia or [tuppercharles@bigpond.com](mailto:tuppercharles@bigpond.com).

---

If undeliverable please return to Post Office Box 827 FYSHWICK 2609 ACT AUSTRALIA

---