

Chapter G

Part II

Hydraulic systems

Hydraulic system mineral oil (LHM)

Applicable to Corniche and Camargue cars from serial number 50 001

Section

- G1m Introduction
- G2m Special precautions
- G3m Hydraulic system pipework
- G4m Bleeding the hydraulic systems
- G5m Hydraulic mineral oil reservoirs
- G6m Hydraulic pumps
- G7m Hydraulic accumulators
- G8m Deceleration conscious pressure limiting valve
- G9m Brake distribution valves
- G10m Brake actuation linkage assembly
- G11m Priority valves
- G12m Height control valves
- G13m Minimum pressure valves
- G14m Gas springs and suspension struts
- G15m Pressure switches
- G16m Front and rear disc brakes
- G17m Parking brake linkage
- G18m Fault diagnosis



Chapter G Part II

Issue record sheet 1

October 1979

The dates quoted below refer to the issue date of individual pages within this chapter.

Section	G1m	G2m	G3m	G4m	G5m	G6m	G7m	G8m	G9m	G10m	G11m	G12m
Page No.												
1	Feb 79	Feb 79	Feb 79	Feb 79	Feb 79	Feb 79	Feb 79	Feb 79	Feb 79	Feb 79	Feb 79	Oct 79
2		Feb 79	Feb 79	Feb 79	Feb 79	Feb 79	Feb 79		Feb 79	Feb 79		Oct 79
3		Feb 79	Feb 79	Feb 79		Feb 79	Feb 79			Feb 79		
4		Feb 79								Feb 79		
5										Feb 79		
6										Feb 79		
7												
8												
9												
10												
11												
12												
13												
14												
15												
16												
17												
18												
19												
20												
21												
22												
23												
24												
25												
26												
27												
28												
29												
30												
31												
32												
33												
34												
35												
36												
37												
38												
39												
40												
41												
42												
43												
44												
45												
46												
47												
48												

Printed in England

© Rolls-Royce Motors Limited 1979

Chapter G Part II

Issue record sheet 2

March 1980

The dates quoted below refer to the issue date of individual pages within this chapter.

Section	G13m	G14m	G15m	G16m	G17m	G18m							
Page No.													
1	Feb 79	Feb 79	Feb 79	Feb 79	Feb 79	Feb 79	Mar 80						
2	Feb 79	Feb 79	Feb 79	Feb 79	Feb 79	Feb 79	Mar 80						
3		Feb 79		Feb 79	Feb 79	Feb 79	Mar 80						
4		Feb 79		Feb 79	Feb 79	Feb 79	Mar 80						
5				Feb 79	Feb 79	Feb 79							
6					Feb 79	Feb 79							
7					Feb 79	Feb 79							
8					Feb 79	Feb 79							
9					Feb 79	Feb 79							
10													
11													
12													
13													
14													
15													
16													
17													
18													
19													
20													
21													
22													
23													
24													
25													
26													
27													
28													
29													
30													
31													
32													
33													
34													
35													
36													
37													
38													
39													
40													
41													
42													
43													
44													
45													
46													
47													
48													

Mineral oil hydraulic system colour coding and component location

Right-hand drive cars

Figure G1m

Printed in England

© Rolls-Royce Motors Limited 1979

February 1979

TSD 4200



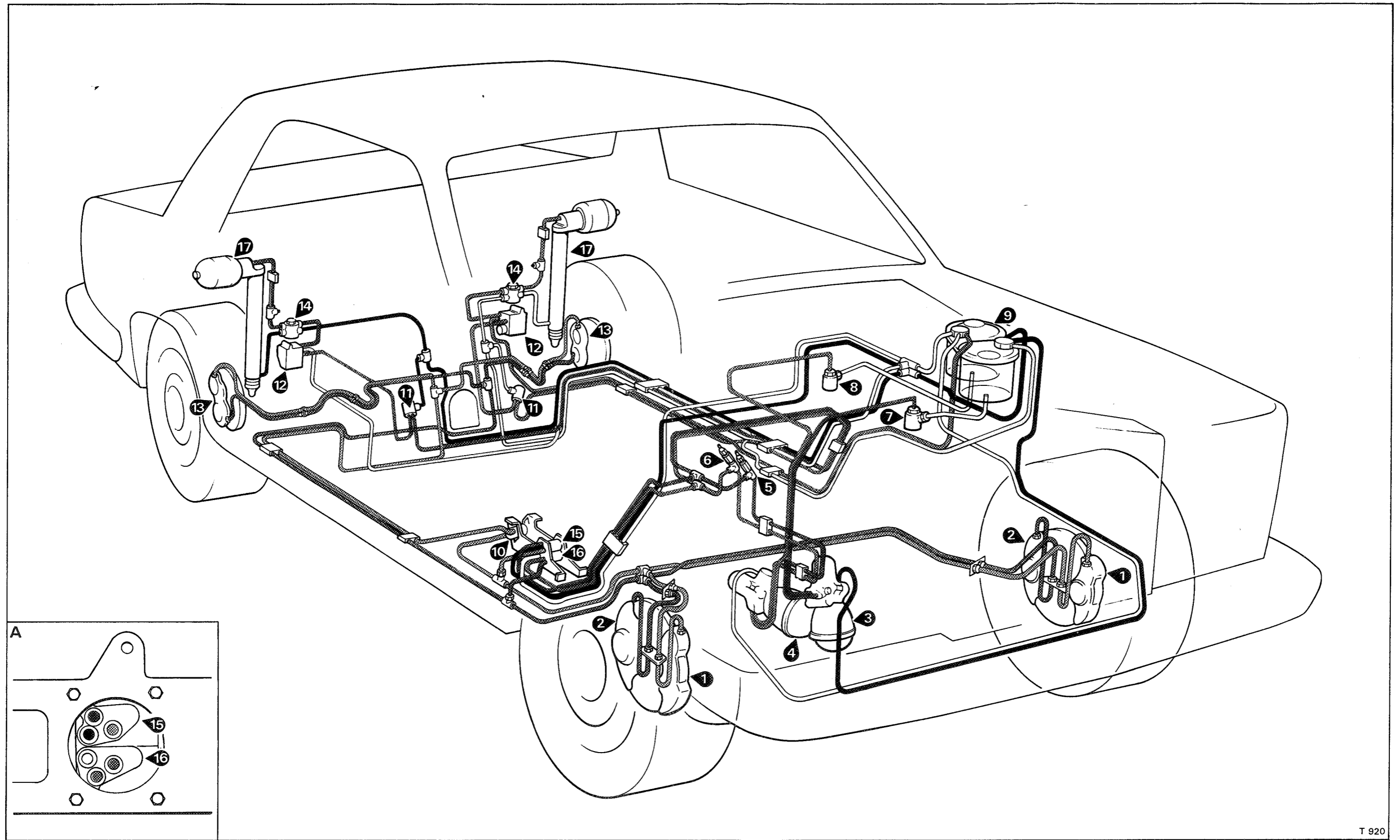

Fig. G1m Mineral oil hydraulic system colour coding and component location (Right-hand drive cars)

- | | | |
|--|---|-------------------------------------|
| 1 Twin cylinder disc brake caliper (No.1 system) | 7 Hydraulic pump (No.1 system) | 14 Minimum pressure valve |
| 2 Twin cylinder disc brake caliper (No.2 system) | 8 Hydraulic pump (No.2 system) | 15 Distribution valve (No.1 system) |
| 3 Hydraulic accumulator (No1 system) | 9 Hydraulic mineral oil reservoirs | 16 Distribution valve (No.2 system) |
| 4 Hydraulic accumulator (No.2 system) | 10 Deceleration conscious pressure limiting valve | 17 Gas spring and suspension strut |
| 5 Pressure switch (No.1 system) | 11 Priority valve | A Distribution valve ports |
| 6 Pressure switch (No.2 system) | 12 Height control valve | |
| | 13 Four cylinder disc brake caliper | |

Mineral oil hydraulic system colour coding and component location

Left-hand drive cars

Figure G2m





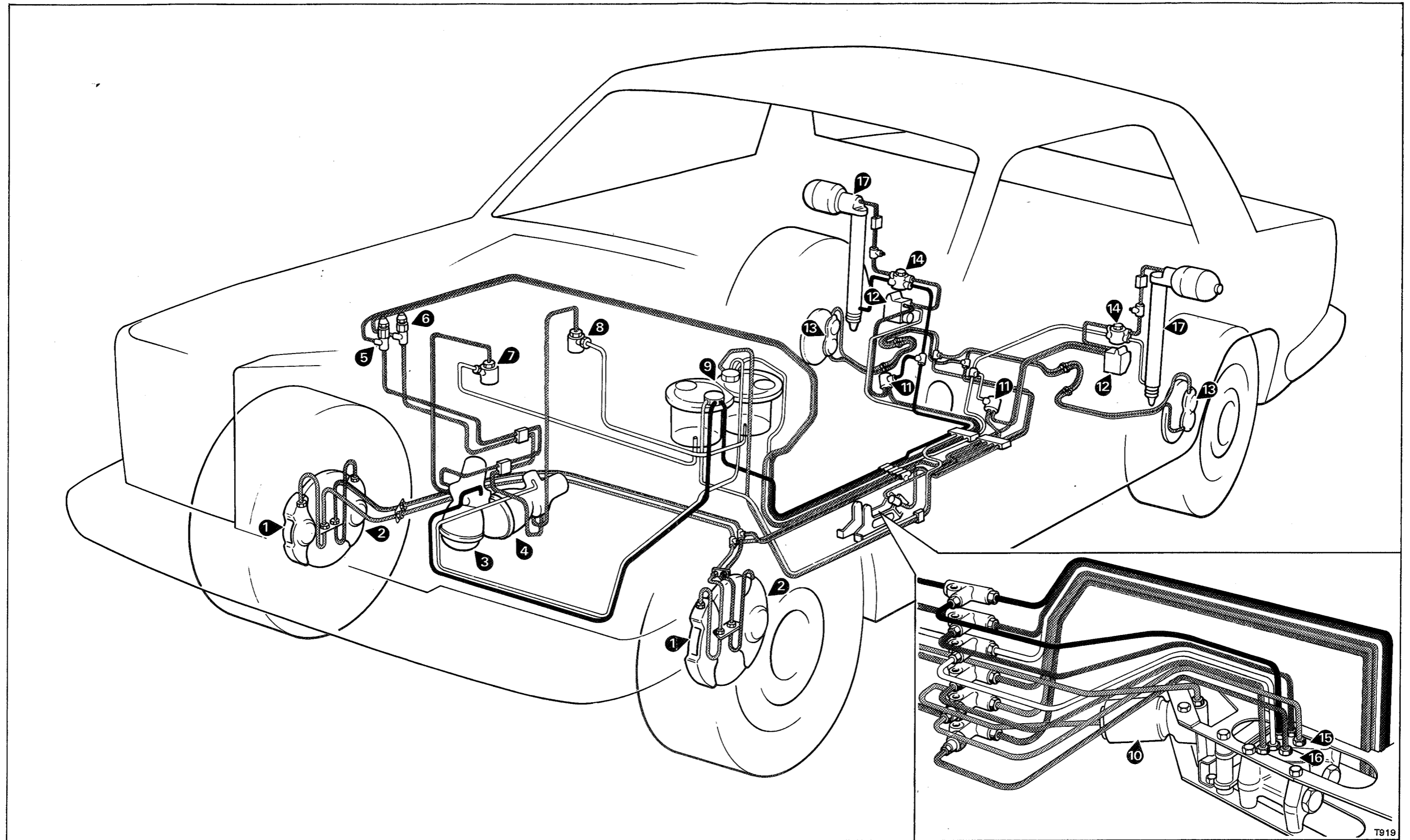

Fig. G2m Mineral oil hydraulic system colour coding and component location (Left-hand drive cars)

- 1 Twin cylinder disc brake caliper (No.1 system)
- 2 Twin cylinder disc brake caliper (No.2 system)
- 3 Hydraulic accumulator (No.1 system)
- 4 Hydraulic accumulator (No.2 system)
- 5 Pressure switch (No.1 system)

- 6 Pressure switch (No.2 system)
- 7 Hydraulic pump (No.1 system)
- 8 Hydraulic pump (No.2 system)
- 9 Hydraulic mineral oil reservoirs
- 10 Deceleration conscious pressure limiting valve
- 11 Priority valve

- 12 Height control valve
- 13 Four cylinder disc brake caliper
- 14 Minimum pressure valve
- 15 Distribution valve (No.1 system)
- 16 Distribution valve (No.2 system)
- 17 Gas spring and suspension strut



Diagram of hydraulic systems

Figure G3m

Printed in England

© Rolls-Royce Motors Limited 1979

February 1979

TSD 4200

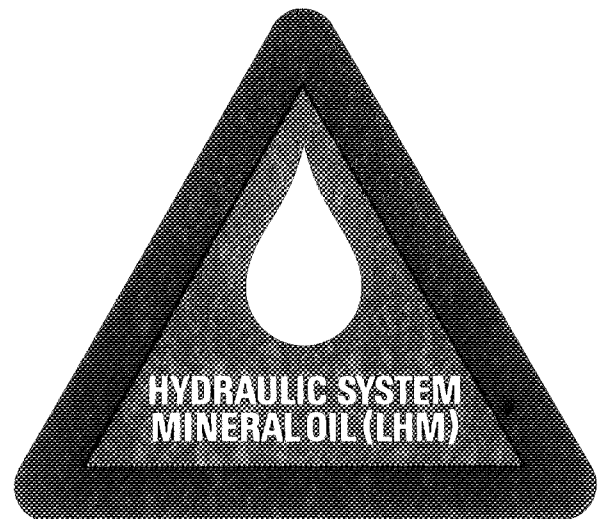



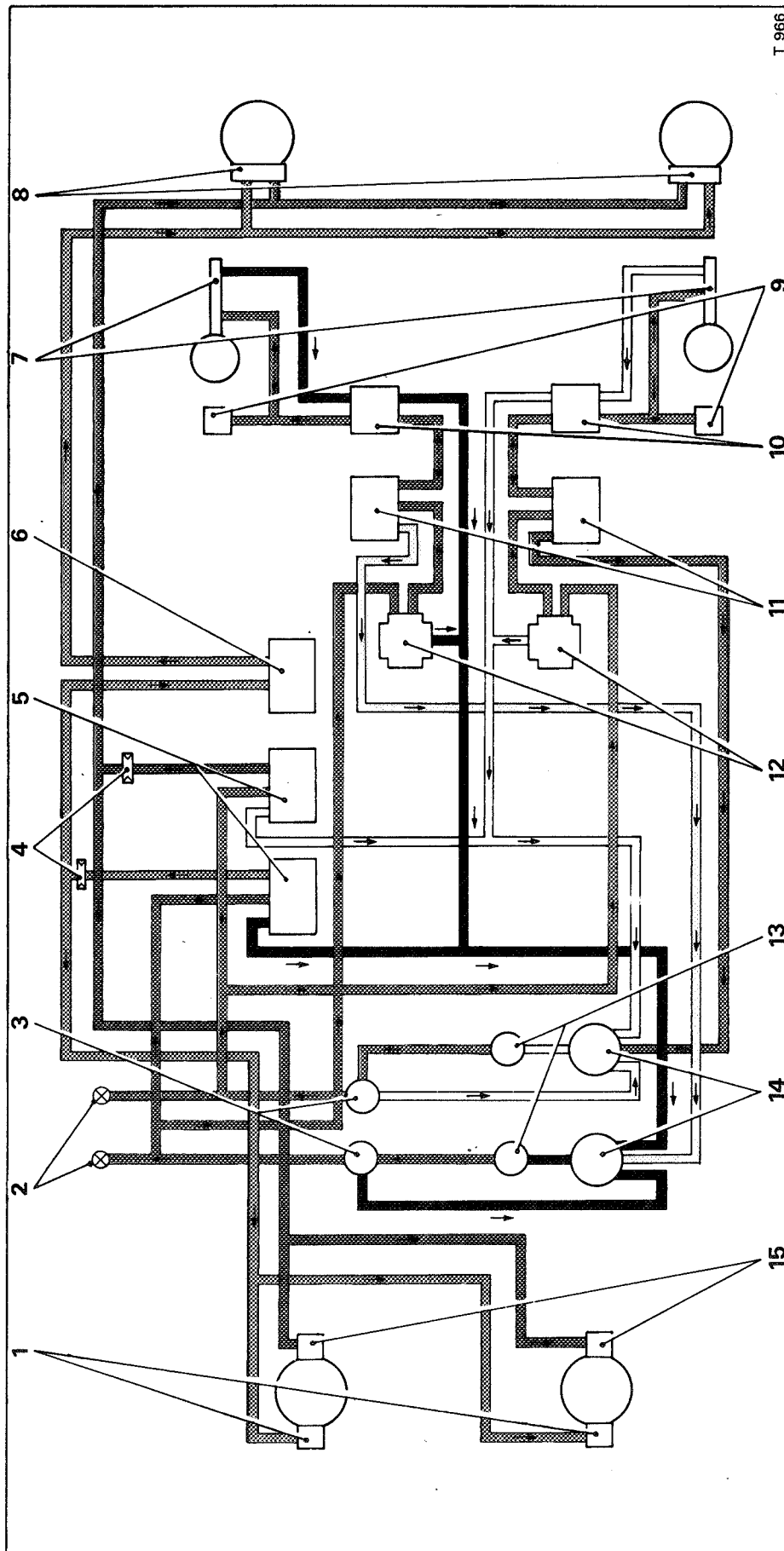

No. 1 Braking and right-hand side levelling system

- High pressure
- Brake line pressure
- Low pressure
- Levelling valve return

No. 2 Braking and left-hand side levelling system

- High pressure
- Brake line pressure
- Low pressure
- Levelling valve return

Fig. G3m Diagram of hydraulic systems

- | | | | |
|----|--|----|----------------------------------|
| 1 | Front wheel front brake callipers | 11 | Levelling valves |
| 2 | Pressure switches | 12 | Priority valves |
| 3 | Hydraulic accumulators | 13 | Hydraulic brake pumps |
| 4 | Restrictors | 14 | Mineral oil reservoirs |
| 5 | Brake distribution valves | 15 | Front wheel rear brake callipers |
| 6 | Deceleration conscious pressure limiting valve | | |
| 7 | Suspension struts | | |
| 8 | Rear wheel brake callipers | | |
| 9 | Suspension strut bleed points | | |
| 10 | Minimum pressure valves | | |

